

DOE/GO/10148--T1

Investigation of an Integrated Switchgrass Gasification/Fuel Cell Power Plant

Final Report

for

Phase I of the
Chariton Valley Biomass Power Project

Submitted to the

U.S. Department of Energy
Biomass Power Program

Prepared by

Robert C. Brown and Jerod Smeenk
Iowa State University

and

George Steinfeld
Energy Research Corporation

September 30, 1998

DISTRIBUTION OF THIS DOCUMENT IS UNLIMITED *ph*

MASTER

TABLE OF CONTENTS

EXECUTIVE SUMMARY	iii
INTRODUCTION	1
BACKGROUND	1
Gasification	1
Fuel Cells	2
Fuel	2
Size	2
Special Characteristics	3
EQUIPMENT AND ANALYSIS	3
Gasifier	3
Latent heat ballast system to produce medium Btu value gas	7
Fuel Cells	8
Classification	8
Types of systems	8
Fuel cell stack performance	10
Power Plants	11
The direct fuel cell	11
Megawatt size power plant design and operation	12
Integration of a biomass gasifier with a fuel cell	14
RESULTS AND DISCUSSION	15
Feedstock characterization	15
Biomass gasification testing	17
Trace contaminants in fuel gas	19
Biomass gasification/fuel cell system analysis	19
Direct carbonate fuel cell power plant	20
Direct carbonate fuel cells on gasified seed corn	20
Direct carbonate fuel cells on gasified seed corn	22
Direct carbonate fuel cells on fuel from an ISU latent heat ballasted gasifier	23
Thermal integration of the gasifier with the fuel cell power plant	24
ECONOMICS OF BIOMASS GASIFICATION/FUEL CELL SYSTEMS	26
CONCLUSIONS	26
REFERENCES	27

EXECUTIVE SUMMARY

The Chariton Valley Biomass Power Project, sponsored by the U. S. Department of Energy Biomass Power Program, has the goal of converting switchgrass grown on marginal farmland in southern Iowa into electric power. Two energy conversion options are under evaluation: co-firing switchgrass with coal in an existing utility boiler and gasification of switchgrass for use in a carbonate fuel cell. This paper describes the second option under investigation. The gasification study includes both experimental testing in a pilot-scale gasifier and computer simulation of carbonate fuel cell performance when operated on gas derived from switchgrass.

Integration of a biomass gasifier with a fuel cell has many advantages. Not least among those advantages is the concept of distributed generation. Due to the dispersed nature of biomass, its relatively low energy content, and high cost of transportation, power plants fueled by biomass are limited in size to 20-25 MWe maximum output. Efficiencies of standard Rankine cycle biomass power plants are low at these scales. However, fuel cell power plants obtain much higher efficiencies, even at small scales. Fuel cells operate at atmospheric pressure which means the biomass gasifier may also run at atmospheric pressure. Atmospheric pressure gasification has proven to be much simpler than pressurized gasification. The similar operating temperatures of the MCFC and the biomass gasifier may enable thermal integration to greater extents. Thus, small-scale distributed generation utilizing IGFC is a promising technology.

Two distinct gasification schemes were investigated. The first was conventional air-blown gasification at atmospheric pressure. Conventional air-blown gasification produces gas with heating value only about 15% that of natural gas. The second gasification scheme employed an indirect heating process developed at Iowa State University. Indirect heating has the advantage of producing gas with heating value approach 45% that of natural gas.

The indirect heating approach uses a single reactor for both combustion and pyrolysis that separates these processes temporally in contrast to the spatial separation employed by other indirect gasification designs. The producer gas is not diluted with the products of combustion or the nitrogen introduced with air. The heat released during combustion is stored as latent heat in the form of molten salt or metal alloy sealed in tubes immersed in the fluidized bed or contained within the walls of the reactor. This heat is released during the pyrolysis stage of the cycle. Preliminary results reveal a producer gas with heating values approaching 450 Btu per standard cubic foot. Producer gas of high heating value and high methane content is desirable for carbonate fuel cells, which internally reforms methane to hydrogen-rich gas, a key process in thermal control of the fuel cell.

The experimental gasification program was performed in a 5 ton per day fluidized bed gasifier. The pilot plant could operate as a conventional air-blown gasifier or, by the addition of a thermal ballast system to the bed, operate as an indirectly-heated gasifier. Fuel handling systems were designed specifically for feeding herbaceous materials like switchgrass into the bottom of a fluidized bed where a significant hydrostatic-like pressure exists. Gas composition was determined via gas chromatography and Fourier Transform Infrared Spectroscopy. Fuels evaluated included switchgrass and obsolete seed corn, the latter serving as a model fuel in evaluating the performance of the gasifier.

The commercial fuel cell power plant presently under development at ERC for utility application has a nominal 2.5 MW rating while operating on natural gas. The net LHV efficiency of the power plant is 53%. This commercial direct carbonate fuel cell power plant is expected in commercial production to have a capital cost of about \$3.5 million. This results in a specific cost of \$1370/kW.

Fuel from an ISU air blown gasifier operating on seed corn has a heating value of 108 Btu/scf (LHV) compared to natural gas, which has a heating value of 933 Btu/scf. These studies quantified that the lower fuel heating value would result in higher gas flow through the ERC commercial natural gas power plant. Due to current design constraints based on natural gas operation, operation on a low BTU gas would require derating the power plant. As a result the power plant is derated to 1647 kW at which power level the gas flow rates are acceptable. Power plant efficiency is 43.7% on the gasified seed corn. Modifications to the standard commercial fuel cell power plant include: a fuel gas compressor capable of delivering 795 scfm, a process to cleanup sulfur and chlorides consistent with impurities from the gasifier, a modified pre-converter capable of methanating the gasified fuel composition and a cooling blower required to accommodate special cooling requirements.

Fuel from an ISU air blown gasifier operating on switchgrass has a heating value of 124 Btu/scf compared to natural gas, which has a heating value of 933 Btu/scf. As in the case of seed corn feed stock the lower fuel heating value would result in higher gas flow through the ERC commercial power plant. As a result the power plant is derated to 1690 kW at which power level the gas flow rates are acceptable. Power plant efficiency is 44.1% on the gasified switchgrass. Modifications to the standard commercial fuel cell power plant include: a gas compressor capable of delivering 1761 scfm, a process to cleanup sulfur and chlorides consistent with impurities from the gasifier, a modified pre-converter capable of methanating the gasified fuel composition and a cooling blower required to accommodate special cooling requirements. The 700°F exhaust temperature offers the opportunity to add a steam bottoming cycle, which would generate an additional 314 kW and raise the plant efficiency to 52.3%.

The additions to the power plant for operation on gasified switchgrass fuel from an air blown ISU gasifier with a lower heating value of only 124 Btu /scf is expected to add about \$200,000 in modifications to the standard plant. Thus for operation on gasified switchgrass the fuel cell plant cost would be \$3.7 million for a 1690 kW net AC output resulting in a specific cost of \$2190/kW.

Fuel from an ISU latent-heat ballasted gasifier operating on seed corn has a heating value of 364 Btu/scf compared the air blown gasifier fuel which has a heating value of 124 Btu/scf. Analysis of the ERC commercial power plant was conducted to evaluate operation on this heating value fuel. Because of the heating value, the commercial ERC fuel cell power plant can produce 2220 kW compared to 2569 kW on natural gas. This represents a 13.6% power derating. Power plant efficiency is 43.7 % on the gasified switch grass. Modifications to the standard commercial fuel cell power plant would include: a fuel gas compressor capable of delivering 795 scfm, a process to cleanup sulfur and chlorides consistent with impurities from the gasifier, a modified pre-converter capable of methanating the gasified fuel composition and a cooling blower required to accommodate special cooling requirements. The 851°F exhaust temperature offers the

opportunity to add a steam bottoming cycle, which would generate an additional 400 kW and raise the plant efficiency to 51.6%.

The additions to the power plant for operation on gasified seed corn fuel from a latent heat ballasted ISU gasifier with a lower heating value of 364 Btu/scf, are also expected to add about \$200,000 in modifications to the standard plant. Thus fuel cell plant cost would be \$3.7 million but the output would be a net 2200 kW resulting in a specific cost of \$1680/kW.

A number of issues concerning integration of subsystems has yet to be addressed. A feed system that can handle a variety of chopped biomass has been developed that shows promise but has not been adequately tested in long-term gasification trials. Only recently has adequate equipment been obtained for characterizing contaminants in the product gas that can poison fuel cell catalysts. A gas clean-up system that can remove these contaminants has yet to be selected.

INTRODUCTION

The Chariton Valley Biomass Power Project, sponsored by the U. S. Department of Energy Biomass Power Program, has the goal of converting switchgrass grown on marginal farmland in southern Iowa into electric power. Two energy conversion options are under evaluation: co-firing switchgrass with coal in an existing utility boiler and gasification of switchgrass for use in a carbonate fuel cell. This paper describes the second option under investigation. The gasification study includes both experimental testing in a pilot-scale gasifier and computer simulation of carbonate fuel cell performance when operated on gas derived from switchgrass.

Options for comprehensive system integration between a carbonate fuel cell and the gasification system are being evaluated. Use of waste heat from the carbonate fuel cell to maximize overall integrated plant efficiency is being examined. Existing fuel cell power plant design elements will be used, as appropriate, in the integration of the gasifier and fuel cell power plant to minimize cost complexity and risk. The gasification experiments are being performed by Iowa State University and the fuel cell evaluations are being performed by Energy Research Corporation.

BACKGROUND

The use of biomass feedstocks as fuel offer many advantages. Concerns over global climate change, fueled by the release of carbon dioxide and other greenhouse gases, make biomass fuels attractive due to the zero net contribution of carbon dioxide, reduced sulfur emissions, and reduction of other hazardous air pollutants (primarily heavy metals). Additionally, biomass waste streams which may normally be landfilled, may be used as feedstocks, thereby reducing the fill rate of landfills. To this end, biomass gasification becomes an attractive alternative for conversion of biomass to alternative fuels in an environmentally friendly manner. Fuels cells are attractive because of their ability to produce electricity from producer gas at high efficiencies and low emissions. The construction of an integrated gasification fuel cell (IGFC) power plant is environmentally friendly and may be economically attractive in certain situations.

Gasification

Iowa State University is currently working with several organizations to evaluate the economic and technical feasibility of using biomass gasifiers in several niche markets, including the use of agricultural wastes to dry seed corn. For the Chariton Valley Biomass Power project, the focus is on switchgrass grown on marginally-productive farm land in southern Iowa. The air-blown gasifier operates at atmospheric pressure and has been operated with a thermal input ranging from 1.8 – 3.5 million Btu per hour.

Atmospheric pressure operation was chosen over a pressurized system for several reasons. First, the complexity of pressurized systems is much greater than atmospheric systems, especially in the feeding of fuel into the reactor. Furthermore, high temperature, pressurized gasifiers are more dangerous than their atmospheric counterparts. Finally, pressurized systems are more costly to construct because of their complexity and the need for additional safety precautions in their design.

The main advantage of a pressurized system arises if it is coupled to a gas turbine for electric power production: cooling and compressing producer gas for this application is avoided. Other

energy conversion systems such as fuel cells, internal combustion engines, or steam cycle technology typically operate at atmospheric pressure or less. Coupling an atmospheric gasifier to these systems is relatively straightforward. Since biomass power will require simple and cost-effective technology, atmospheric gasifiers are indicated. European experience with both atmospheric and pressurized gasifiers also support the development of atmospheric biomass gasifiers for distributed power applications.

Fuel Cells

Fuel cells have the potential to have significant impact on utilities in the future. The deregulation of the industry is expected to create opportunities for fuel cells that did not previously exist. This will arise simply as freedom of choice begins to find its way into mainstream customer thinking. Utilities themselves are most likely to benefit from the fuel cell and its characteristics or they may, in certain instances, find the fuel cell in the hands of its competitors.

For a fuel cell to be beneficial, it will have to be both reliable and cost competitive. At present, cost competitiveness is the biggest challenge. Like any new product, providing a potentially better but not a totally unique, service, the fuel cell is faced with the volume-price conundrum. Different approaches to finding a solution to this problem are being pursued. For electric utility applications, it is possible to set a few basic ground rules.

- Fuel

First, the fuel cell power plant must be able to operate on a readily available fuel. The fuel of choice is natural gas. The Department of Energy's Energy Information Agency projects that between now and 2015, 80% of new power plants will be fueled by natural gas. The second choice for fuel is, of course, coal. Coal occupies this position because it is presently the most used fuel and is abundantly available in the U.S. For use in the fuel cell, however, it needs to be gasified and that technology is still not yet widely available commercially.

Other fuels that are less readily available but may become interesting candidates are landfill gas, other agricultural wastes and biomass, but like coal gasification, up front processes are required which are also not readily available or fully developed. It is for this application (biomass gasification) that this study is directed.

- Size

To make an impact in the utility market, and more specifically, the electric utility markets, the fuel cell power plants will most likely have to be in the megawatt class. Even for distributed generation or use in conjunction with or in place of a substation, it is hard to imagine utility interest from a dispatch viewpoint for anything less than one or two megawatts. Also from an economic standpoint, it is probably not likely that fuel cell power plants less than one megawatt would be cost competitive except in very special utility situations.

For the near term, it is likely that the market for fuel cells within the electric utility framework will lie between 1 and 20 MW and perhaps only in the 1 to 10 megawatt range. In larger sizes,

50 to 100 MW, it will be hard to compete in the near term with the relatively clean and efficient and presently less costly combined cycle gas turbines. Still, the market for fuel cells is potentially very large indeed.

- **Special Characteristics**

In the new to be deregulated utility business, service as well as energy will be a product. If we believe this, a product will be sought which can provide special features. Fuel cells offer a variety of special characteristics that either utilities or their competitors may seek to employ.

For example, power quality. A fuel cell via its inverter can provide either leading or lagging VAR control. A fuel cell can provide special power quality required by certain manufacturing industries. A fuel cell can provide a power source more independent of the uncertainties of weather impact on power lines by locating it near a customer. Fuel cells are modular and can offer both utilities and industry the option of phased capacity addition without suffering a fuel efficiency penalty. This, in turn, can reduce planning risks and improve cash flow for the provider.

Fuel cells have clean and quiet features as we demonstrated on a megawatt scale with our recent power plant in Santa Clara, CA. It is not likely that these features will be matched by rotating machinery in this size range in the foreseeable future, if ever. Since fuel cells are clean, quiet and modular, they can be located near or at a customer's site, thus opening the possibility for cogeneration. This feature can reduce the effective cost of electricity by attaching value to energy that would otherwise be wasted.

While virtually all fuel cells currently under development or in the process of being commercialized share many of the same characteristics with respect to features such as power quality and modularity, they are probably not the same with respect to cost, fuel efficiency and cogeneration characteristics.

EQUIPMENT AND ANALYSIS PROCEDURES

Gasifier

A photograph of the BECON fluidized bed gasification pilot plant is shown in Figure 1. The reactor measures 18 inches in diameter and 8 feet in height. The reactor is lined with a nominal one inch thick layer of refractory. The refractory liner serves two purposes. First, the refractory protects the shell of the reactor (constructed of mild steel) from the harsh environment of the gasification process. Second, the refractory reduces heat loss from the reactor. As such, increasing the thickness of the refractory would increase reactor efficiency; however, this additional thermal mass would greatly increase start-up and shut-down times. As this is a demonstration unit, a relatively thin layer of refractory was employed to minimize start-up time.

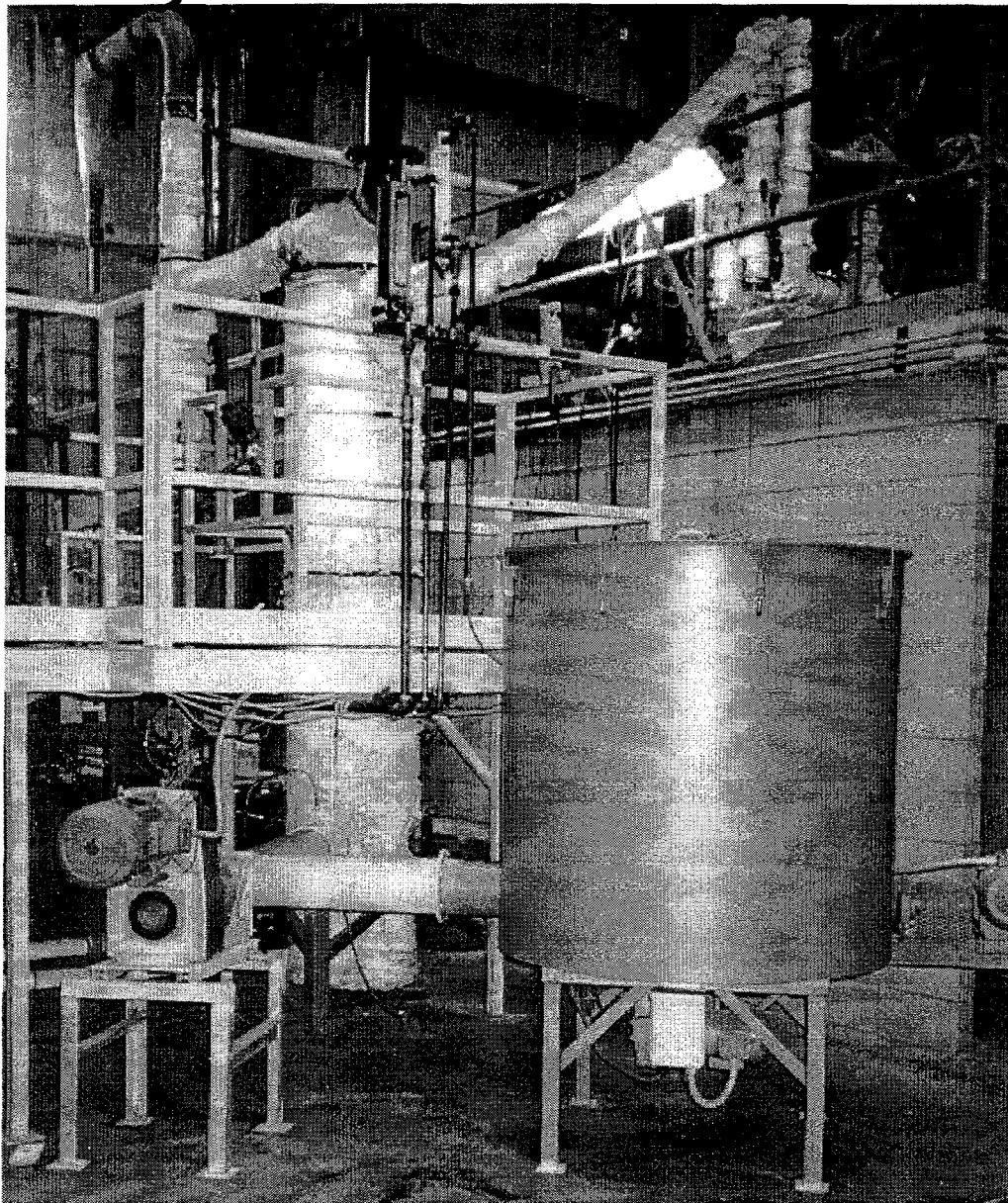

Figure 1. Picture of the 5 ton-per-day biomass gasifier located at Iowa State University.

The distributor is a drilled plate with 225 $\frac{1}{8}$ inch diameter holes spaced at 1 inch (square pitch). This type of distributor is appropriate for small fluidized bed reactors but may not be the best option for larger reactors. Two overflow ports located 24 and 36 inches above the distributor plate allow overflow of bed material which may accumulate if the biomass feedstock has a large percentage of ash. Thirty access ports accommodate temperature and pressure measuring devices. A sight port, located in the freeboard portion of the reactor, allows the surface of the fluidized bed to be observed during start-up. Natural is used during start-up to heat the reactor to gasification temperatures. Compressed air is used for fluidization of the bed and partial oxidation of the fuel. Air flow rates are measured using an orifice plate with an electronic pressure transducer.

The initial material handling system was designed to feed flowable biomass materials, i.e., obsolete seed corn. Many gasification tests have been performed using obsolete seed corn. Energy Research corporation has performed a system simulation with seed corn as the fuel. These results are discussed below. The reactor operates with forced draft air supply which results in a slight positive pressure in the reactor. At the point where fuel is injected the pressure is typically 40-50 inches of water column. Although the pressure is relatively small compared to pressurized systems, it is large enough to present hot gas sealing problems between the gasifier and fuel feed system. A simple rotary airlock worked adequately for flowable fuels. Switchgrass, however, does not flow easily, has a low bulk density, and is stringy.

Two distinct feed systems were constructed during the course of this project to feed switchgrass into the bottom of a fluidized bed. The first feed system, shown in Figure 2, was used to generate the data in this report. It consists of a metering bin, a rotary airlock, an injection screw, and an exhaust fan. The metering bin consists of two nine inch counter rotating screws designed to prevent bridging of herbaceous materials. The metering bin functioned reasonably well but required almost constant supervision to ensure a uniform feed. The airlock, constructed of steel vanes with rubber wiping strips, does not make up the entire pressure differential between gasifier and hopper. The injection auger is stainless steel and rotates at 30 rpm.

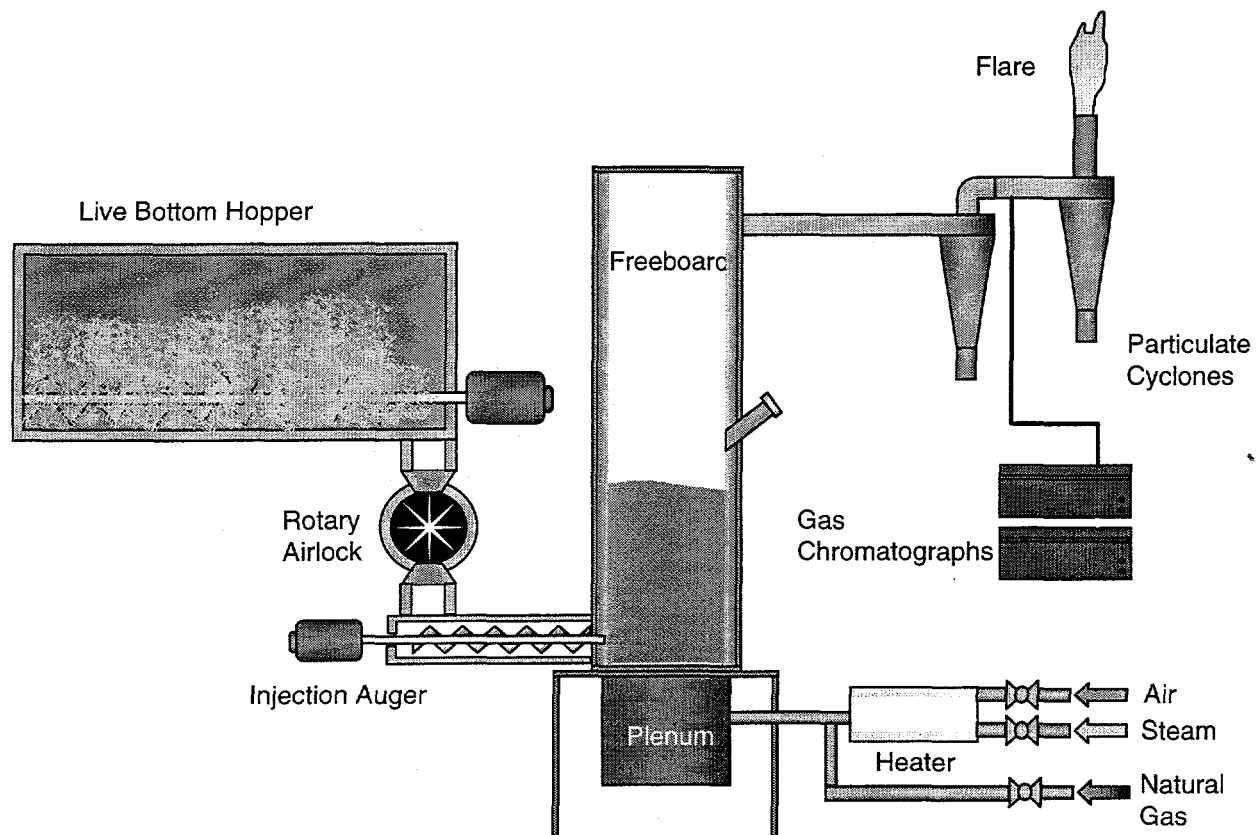

Figure 2. Schematic of the fluidized bed gasifier with first generation switchgrass feed system.

Stalks of switchgrass were prone to jamming the rotary airlock, allowing hot gas to flow back through the feeder system. Tarry deposits on the inside of the feed chute originating from this

back flow eventually hampered the movement of switchgrass through the feed system. The exhaust fan serves to collect the smoke and other exhaust gases which leak back through the system. A large quantity of make-up air is injected below the airlock to minimize the amount of producer gas flowing back through the system. This system operated satisfactorily for short duration runs on switchgrass gasification and allowed adequate data to be collected for producer gas characterization.

A second switchgrass feed system was designed and installed for more reliable operation during extended tests planned for the future. This system is shown in Figure 3. The new system also utilizes dual augers to feed switchgrass. A variable speed six inch auger removes material at the specified rate from a 50 cubic foot hopper. The metering auger feeds the biomass directly into the injection auger. The high-speed, stainless steel injection auger injects the biomass into the fluidized bed reactor slightly above the distributor plate. Preliminary testing of the new system show favorable results. Switchgrass feed was more uniform and producer gas back flow was minimized. Currently the hopper is sealed to prevent back flow of hot gases, eliminating the need for a rotary airlock. This limits tests to approximately 45 minutes. Plans are underway to enable continuous feeding of biomass fuels.

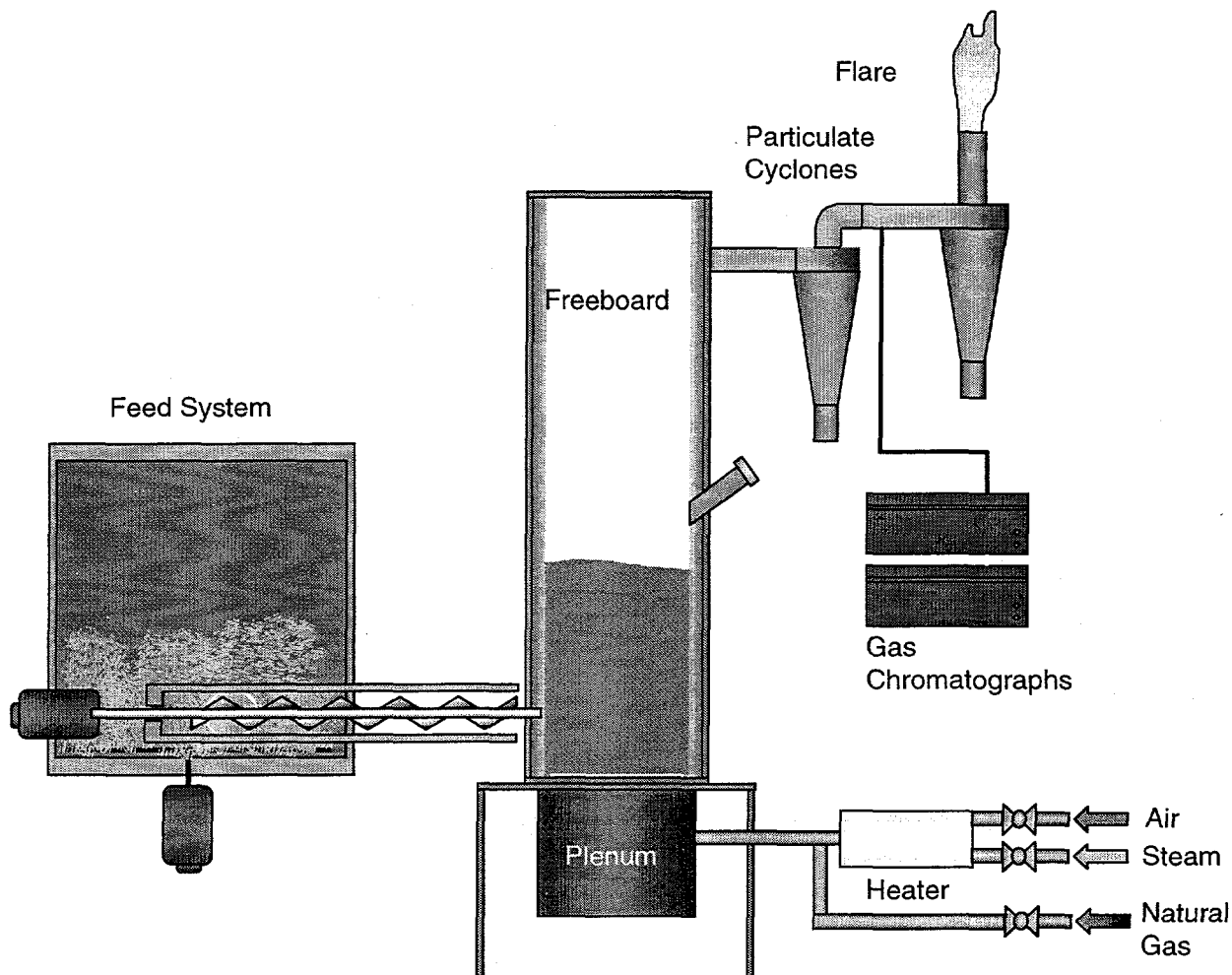

Figure 3. Schematic of the biomass gasifier with second generation switchgrass feed system.

Exhaust gases exit from the top of the freeboard, flow through two cyclones in series to remove particles, and exit the building where the product gas is flared. Each cyclone is designed to remove 50% of particles 7.5 microns (μm) in diameter or larger. The exhaust gas is ignited in a diffusion flame by an electric igniter. Sampling equipment was installed in the dipleg of the first cyclone to sample cyclone catch during operation. A sample of exhaust gas is withdrawn at the gas-stream exit of the first cyclone and cleaned and dried prior to being injected into gas chromatographs (GCs) and a Fourier Transform Infrared Spectrometer for gas analysis.

Temperatures and pressures are monitored and recorded by a data acquisition system, which also controls the air flow and fuel feed into the reactor. Temperatures are measured in the plenum, along the axis of the reactor, in the freeboard, and at the cyclone inlet by Type K thermocouples. Stainless steel pressure taps also mounted along the axis of the reactor allow measurement of pressure gradient across the fluidized bed. The pressure gradient across the fluidized bed is a diagnostic tool for monitoring the hydrodynamic behavior of the bed. Variations in the bed pressure gradient may indicate abnormal fluidization in the reactor due to agglomeration or segregation of bed material. The data acquisition and control (DAC) system is comprised of a personal computer (PC) with a DAC board and an external chassis which houses several different DAC modules. Input and output signals are connected to the system through the modules in the chassis. The external chassis is a signal conditioning interface with the PC.

Latent heat ballast system to produce medium Btu value gas

In a conventional gasifier, partial combustion of the solid fuel entering the gasifier provides the energy needed to drive endothermic reactions present during conversion of biomass into combustible gas. Air is generally used as the oxidizing agent for this partial oxidation process. However, use of air during gasification dilutes the producer gas due to its high nitrogen content, significantly lowering the heating value of the producer gas. If the gas is to be used in a prime mover, such as gas turbines, internal combustion engines, or fuel cells, it is desirable to maintain as high a heating value as possible. Air can be eliminated from the process only if an alternative source of heat is employed. This process is called indirectly-heated gasification.

Gasification usually consists of two distinct processes: combustion and pyrolysis. Pyrolysis is the chemical decomposition of solid fuel at elevated temperatures to produce a combustible gas mixture. Since pyrolysis is an endothermic reaction, it must be accompanied by a heat source, typically partial combustion of the fuel. The conventional approach to gasification allows combustion and pyrolysis to proceed simultaneously in the same reactor. If combustion is supported by air, then the producer gas contains a large proportion of non-combustible gases (nitrogen and carbon dioxide) which greatly degrades the heating value of the gas. If combustion is supported by pure oxygen, the heating value of the producer gas is greatly improved. However, the use of oxygen is prohibitively expensive except in gasification plants that are much larger than is practical for dispersed biomass resources.

A gasification scheme utilizing indirect heating that greatly improves the heating value of producer gas without the use of oxygen has been developed at Iowa State University. The approach uses a single reactor for both combustion and pyrolysis that separates these processes temporally in contrast to the spatial separation employed by other indirect gasification designs. The producer gas is not diluted with the products of combustion or the nitrogen introduced with

air. The heat released during combustion is stored as latent heat in the form of molten salt or metal alloy sealed in tubes immersed in the fluidized bed or contained within the walls of the reactor. This heat is released during the pyrolysis stage of the cycle. Preliminary results reveal a producer gas with heating values approaching 450 Btu per standard cubic foot. Producer gas of high heating value and high methane content is desirable for carbonate fuel cells, which internally reforms methane to hydrogen-rich gas, a key process in thermal control of the fuel cell.

Fuel Cells

- Classification

Fuel cells can be classified in various ways. Most commonly, their fuels, electrolytes or temperatures are used. For example, we might speak of a methanol fuel cell, or a high temperature fuel cell, or a phosphoric acid fuel cell. From this point on, the discussion will be limited to natural gas as fuel since this fuel will probably dominate new utility power plants for the next 20 years. Since electrolytes mean more to electrochemists than power plant engineers, we will use operating fuel cell stack temperatures as the classification means.

There are four basic fuel cell technologies that are expected to be compatible with a natural gas feed stock: low temperature, 60-80EC; intermediate temperature, 180-200EC; high temperature, 600-650EC; and very high temperature, 1000EC. These latter two are commonly called advanced fuel cell technology. Each one of these technologies of necessity uses a different electrolyte. The electrolyte in a fuel cell plays the same role as the sulfuric acid in a car battery, it separates the electrodes and conducts electricity ionically.

- Types of Systems

In a fuel cell of any kind, the natural gas, mainly methane, and oxygen from the air do not ever come into direct contact with each other. They react indirectly, galvanically, via the electrolyte.

Now there is a great abundance of natural gas on earth. This suggests that it is not very reactive. There is also about 20% oxygen in our atmosphere and fortunately, it is also not very reactive. Normally, in a conventional power generation process, the temperatures of the fuel and air are raised to a level where in direct contact with each other combustion takes place and heat is produced. In a fuel cell, reactants never meet and besides, we do not want heat, we want electricity generated electrochemically. And thus in different types of fuel cells, different means are used to make the desired electricity producing reactions happen.

The reactions are made to take place using catalysts. However, it is extremely difficult to make methane react electrochemically. The most common approach to fuel cell power plant design is to produce hydrogen from natural gas by a separate process - and the most common process (not the only one) is by steam reforming usually done in catalytic reactors outside the fuel cell as part of the balance of plant.

Steam reforming is a chemical catalytic process and as the name suggests, it is a reaction of steam and methane to produce hydrogen, carbon dioxide and carbon monoxide in accordance

with very well known thermodynamic and kinetic theories. Because methane is so inert, the process must take place at elevated temperatures about 800EC. It is now apparent that the operating temperatures of the different fuel cells will result in significant variations in power plant design to accommodate fuel processor fuel cell integration.

The very high temperature fuel cell and the high temperature fuel cell which operate above and/or near the fuel processor operating point can transfer waste heat directly into the endothermic fuel processor or reformer. The intermediate and low temperature fuel cell must transfer heat from a low temperature to a much higher level. But there is even further variation. The intermediate temperature fuel cell can use its fuel cell waste heat to raise steam needed for the reforming reaction. The low temperature fuel cell must seek other sources of energy to sustain both steam generation and reforming processes.

The two most basic approaches to fuel cell power plants are shown in Figure 4. Traditionally, an external fuel processor is used to generate hydrogen for fuel cell use. In the case of the Direct Fuel Cell, this step is incorporated into the fuel cell stack in one of several ways. The difference between these two approaches impacts power plant design, especially the balance of plant.

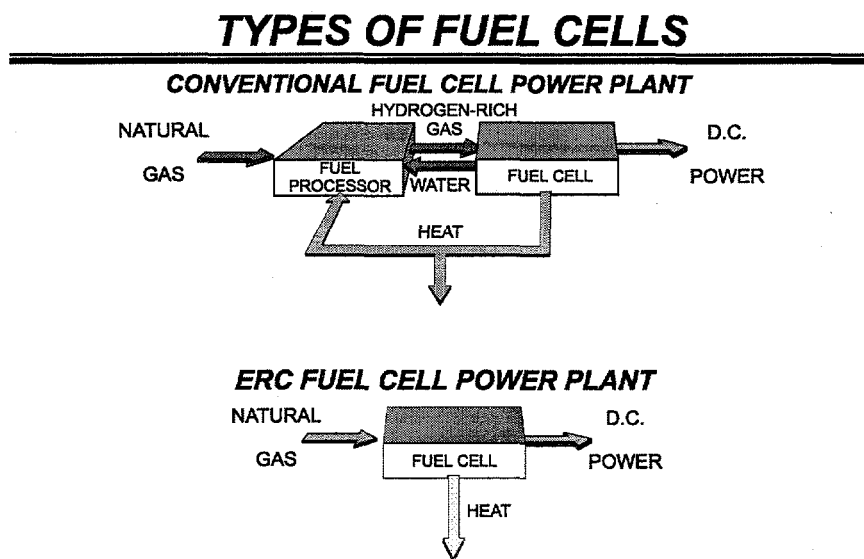

Figure 4. Basic approaches for fuel cell power plants.

MO248AX

In Figure 5, we show generic system designs for various types of fuel cells. From this figure, it is apparent that the variations in balance of plant (BOP) equipment will have a substantial impact cell, more specifically, the Direct Fuel Cell, which is being pursued by ERC, we estimate that the on power plant operations, efficiency and cost. For the most part, all the power plants contain equipment operating over the same general temperature ranges even though the fuel cells themselves operate at very different temperatures. For one variation of the high temperature fuel balance of plant will represent about two-thirds of the initial capital cost. The Direct Fuel Cell has no equipment operating above 650°C and contains a relatively simple BOP.

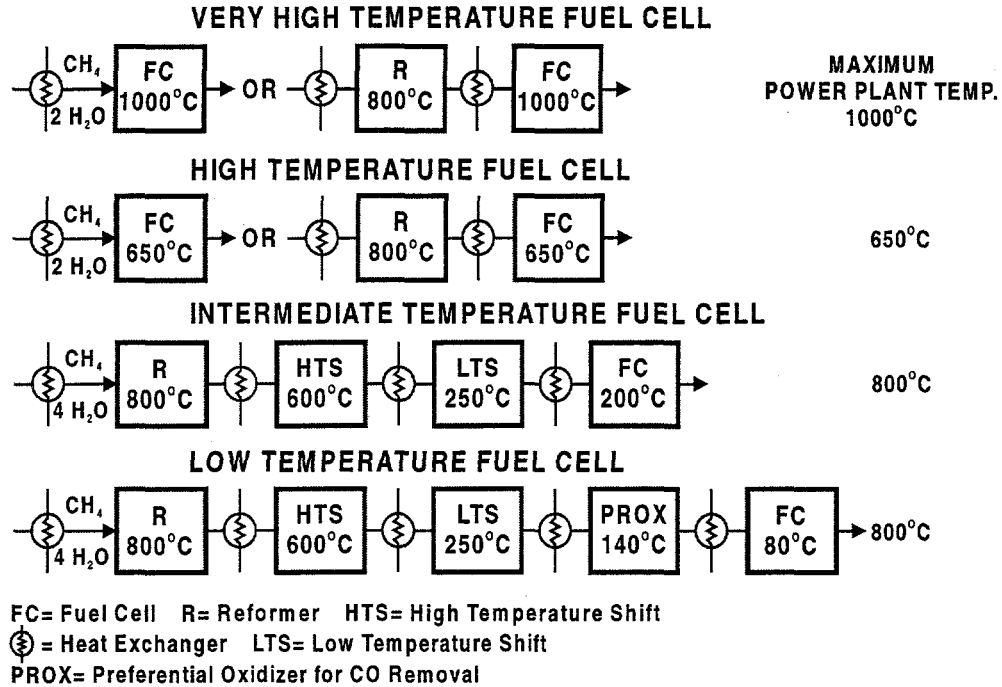

Figure 5. Generic system designs for different types of fuel cells.

- Fuel Cell Stack Performance

In Table 1, we summarize the relative performance of different fuel cell stacks. The basis for this table is a natural gas fuel cell stack operating at ambient pressure at a practical fuel utilization in the 75-85% range. It is interesting to note that most expected fuel cell stack performance is similar within reasonable limits. Moreover, it is expected that the different fuel cell stacks will have similar costs per kilowatt even though the materials of construction are quite different as shown in Table 2. This leads one to the general conclusion that the BOP may well become the important cost driver in utility power plants.

Table 1. Estimated Performance of Fuel Cell Stacks*

Temperature	CD Range, A/FT ²	Voltage Range
Low ¹	160 - 350	.65 - .75
Intermediate	100 - 400	.60 - .75
High	160 - 300	.64 - .78
Very High ²	200 - 400	.50 - .75

*Normalized with respect to fuel, pressure, utilization, etc.

Table 2. Fuel Cell Stack Materials of Construction

<u>Temp. Material</u>	Low	Inter-mediate	High	Very High
Precious Metal Catalyst	√	√		
Non-Precious Metal Catalyst			√	√
Graphite	√	√		
Ceramic		√	√	√
Metals	*		√	√
Special Organics	√			

* In some designs, metals can be used instead of graphite

Power Plants

- The Direct Fuel Cell

As previously discussed, the more traditional approach has been the production of hydrogen fuel in external equipment. In the case of the Direct Fuel Cell, which ERC uses with its high temperature fuel cell, all reactions chemical plus electrochemical, take place inside the fuel cell stack itself at the 600 to 650°C operating temperature of the fuel cell. Even though conventional fuel processing usually takes place in the indicated 800°C range, inside the direct fuel cell the fuel is being consumed and product steam and heat is being generated at 650°C. The combination of fuel consumption and steam generation means that the chemical reactions taking place are not in equilibrium but rather driven to completion by the electric current produced by the fuel cell itself in the direction favoring complete chemical conversion of the methane fuel at lower than the normally expected temperature. This avoids heat exchangers, reformer and its special materials required for the 800°C operation and thus saves capital costs. More important, however, is the fact that the reforming reaction is endothermic. When it is incorporated inside the fuel cell stack, it serves to cool the stack, improving the temperature distribution and power output, while minimizing parasitic power requirements.

In developing the Direct Fuel Cell, ERC has conducted a number of field tests beginning with a small scale demonstration of a fully integrated grid connected natural gas test at the site of an Elkraft Power Co. power plant in Denmark in 1989. This was followed by a natural gas 70 kW demonstration at a PG&E Corporation site in San Ramon, CA in 1991-1992 time period. Two other demonstrations on natural gas were conducted at Elkraft in 1994 and 1996. In the 1993-94 time frame, a coal gas demonstration was done under Electric Power Research Institute (EPRI) sponsorship at the Destec Energy Inc. site in Plaquemine, LA. That test, along with 120 kW

tests at ERC were described in our 1994 American Conference Paper³. We have come a long way since that presentation.

- Megawatt Size Power Plant Design and Operation

The largest Direct Fuel Cell Demonstration – 2 megawatts – began in April 1996, the Santa Clara Demonstration Project, and as the name suggests, is taking place in Santa Clara, CA. This project represents an excellent example of cooperation between industry and government. The utility industry as represented by the City of Santa Clara Electric Department, the Los Angeles Department of Water and Power, Edison International, Sacramento Municipal Utility District, the City of Vernon, California, and the National Rural Electric Cooperative Association, represented by United Power Association, the Salt River Project, Northern California Power Agency and EPRI provided support for the BOP and testing, about 60% of the project cost and the Department of Energy as represented by the Federal Energy Technology Center (formerly the Morgantown Energy Technology Center) funded the fuel cell stack modules.

The power plant system is shown in a simplified form schematically in Figure 6. The power plant contains two 1 MW sections each containing two 500 kW modules. Each module contains four 125 kW stacks consisting of 258 cells. The power plant covers approximately 1 acre in area inclusive of a control room and conference rooms. A brief description of activities is given below and a list of achievements, firsts and records is given in Table 3.

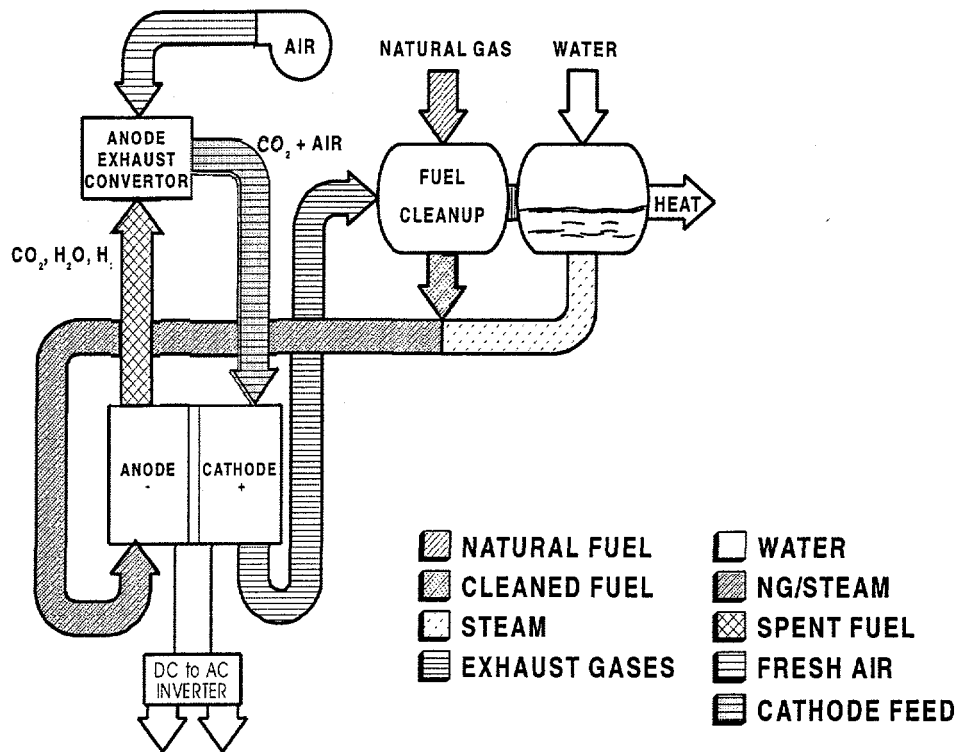

FCE68B
01297

Figure 6. Simplified fuel cell power plant process flow diagram.

Table 3. SCDP Achievements

<ul style="list-style-type: none"> • World's largest advanced fuel cell power by an order of magnitude • Largest fuel cell power plant operated in the United States • Achieved 44 percent efficiency level, a record for a fossil fuel power plant of this size • SO_x below detection limits and 2 ppm NO_x emissions • Meets Santa Clara 70 decibel noise specifications with no special sound proofing provisions 	<ul style="list-style-type: none"> • Instantaneous load shed capability • 3 percent/minute ramping capability demonstrated • Over 3,400 hours of grid connect power • Reached 1.93 MW AC, 7 percent higher than rated power • Valuable information on power allocation among fuel cell stacks • Virtually flawless balance-of-plant operation has been proved over the first 4,900 hours of operation • Insight gained into future power plant electric configuration
--	--

The power plant startup was smooth after some minor adjustments to the DC to AC inverter unit. The power plant surpassed its 1.8 MW AC design goal by reaching a peak power of 1.93 MWAC. About 550 hours into the test, peculiar electrical behavior was observed. Voltage spikes were randomly observed and we chose to shut down the power plant in order to check out the phenomena and avoid any possible damage to the digital control system. On examining the plant, it was determined that the dielectrics in the piping system used to electrically insulate the fuel cell stacks' high voltage had been damaged.

The cause of the problem was the use of a glue to attach thermal insulation to the stacks, pipes and dielectric insulators. This glue, applied during the final stage of manufacturing, was converted to carbon during plant startup. The carbon acted as a conductor, negating the effectiveness of the electrical insulators. The result was damage to dielectrics and other components. We replaced the four highest voltage dielectrics and certain piping, cleaned the carbon from the remaining dielectrics and made repairs where there was visible evidence of damage. A decision was made not to remove certain parts for further inspections in the interest of saving time and costs. To a certain extent, using the glue has prevented making an unambiguous assessment of the fuel cell performance in the power plant.

The power plant was restarted, achieved a level of 1.25 MW but was prevented from higher levels by reduced performance of certain stacks. On this basis, it was decided to reconfigure the power plant into an 8 stack 1 MW unit. The Company believes that the initial event relating to the glue incident might have caused greater damage than originally anticipated. The stacks' reconfiguration was accomplished in the field in a 10 hour period and the power plant was put back on line, after the addition of a new AC to AC transformer. Through January 4, 1997, the plant was at 750 kW or 75% of rated power for the 1 megawatt plant. One stack out of eight was at a slightly lower performance than the others. The plant has already operated over 3,375 hours

of grid connected time. Total operating time is 6,900 hours with 4,900 hours of hot time and it has delivered 1550 MWH net AC power to the Santa Clara grid. In the second week of January 1997, the power plant was placed in a hot standby condition to perform maintenance on a balance of plant component. The maintenance was completed in about ten hours and the power plant was put back in grid connected mode but could not sustain a 725 kW load. The power plant was placed on half load, 500 kW, to the end of the test.

A second demonstration is planned at the site of our corporate headquarters in Danbury, CT. It is planned to contain one megawatt size (1.1 to 1.4 MW) module. The BOP piping is designed to be reduced by 90%. The module will contain larger stacks both in area and height. A model of the commercial power plant containing two such modules is shown in Figure 7. This power plant is expected to occupy approximately one-ninth the footprint and deliver up to 50% higher power than the California power plant.

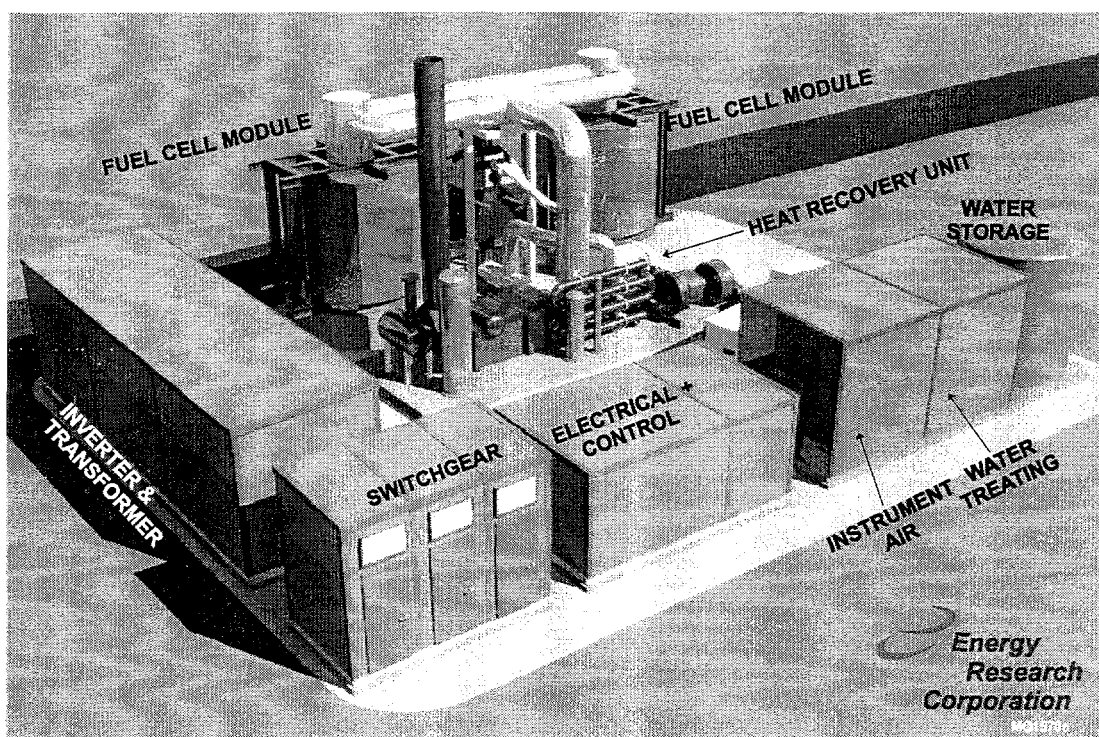

Figure 7. Model of commercial power plant.

Integration of a biomass gasifier with a fuel cell

As described above, integration of a biomass gasifier with a fuel cell has many advantages. Not least among those advantages is the concept of distributed generation. Due to the dispersed nature of biomass, its relatively low energy content, and high cost of transportation, power plants fueled by biomass are limited in size to 20-25 MWe maximum output. Efficiencies of standard Rankine cycle biomass power plants are low at these scales. However, fuel cell power plants obtain much higher efficiencies, even at much smaller scales. Fuel cells operate at atmospheric pressure which means the biomass gasifier may also run at atmospheric pressure. Atmospheric

pressure gasification has proven to be much simpler than pressurized gasification. The similar operating temperatures of the MCFC and the biomass gasifier may enable to greater extents thermal integration. Thus, small-scale distributed generation utilizing IGFC offers to be a promising technology.

Many issues and potential difficulties exist in the integration of a biomass gasifier with a fuel cell. The most notable of these difficulties is the quality of the fuel gas provided to the fuel cell. Fuel gas may contain many different contaminants that may poison fuel cell catalysts. Known contaminants include chlorine, sulfur, arsenic, selenium, zinc, lead, and tars. High concentrations of chlorine may be evident in biomass fuels, particularly fast growing biomass (such as switchgrass). The chlorine is typically tied up as salts in the biomass but may be found in the producer gas as potassium chloride, sodium chloride, or hydrogen chloride. In any case, chlorine compounds will need to be removed to < 0.1 ppm for long term operation without detrimental affects to the fuel cell catalyst. Biomass typically has very little sulfur. However, sulfur concentrations > 0.5 ppm will be detrimental to fuel cell operation. Sulfur in the producer gas will most likely be in the form of hydrogen sulfide. It is not likely that there will be arsenic, selenium, zinc, or lead in the vapor phase due to their low volatility at gasifier temperatures. Tars, however, may be problematic as they form a soot layer on fuel cell catalyst. It has been experimentally determined the concentrations < 1 % by volume of light hydrocarbons may be acceptable. However, fluidized bed gasifiers typically generate 4-8% condensable tars; thereby requiring some tar decomposition or removal.

RESULTS AND DISCUSSION

Feedstock Characterization

A detailed analysis of the switchgrass was performed. The analysis may be found in Table 3. This analysis is valuable for several reasons. First, the analysis was performed on unashed samples. This is important because many trace elements of concern (i.e., chlorine, sodium, potassium, etc.) may volatilize during ashing and therefore would not be accounted for in an analysis of the ash. Second, identification of contaminants in the unashed sample of biomass will give an indication of what clean-up methodologies will need to be developed depending on the end use of the producer gas. For example, if the gas is to be utilized in a fuel cell, contaminants of interest include sulfur, chlorine, arsenic, selenium, zinc, and lead. If these constituents are not found in the original switchgrass sample then there is no need to develop gas clean-up for their removal. The data on switchgrass indicates high values for chlorides and sulfur, which suggests that chloride and sulfur removal will be required as part of the clean-up system. In addition, the potassium content will help to catalyze the gasification process. Standards (apple leaves and pine needles) were analyzed as unknowns for quality control purposes. The certified values are listed adjacent to the analyzed values.

Table 4 is an analysis of switchgrass ash. The ash was generated by heating the original sample to 480 °C (896 °F). A comparison between of the trace elements of interest (i.e., potassium) from the original sample and the ashed sample show little change due to the ashing process. This is expected as the ashing temperature was not hot enough to volatilize a significant portion of the trace elements of interest. Unfortunately there is not information in the ash analysis on chlorine,

sulfur, or lead content which are all elements of interest. Studies on straw conducted at the Danish Technological Institute suggest that at 480 °C only 10% of the alkalis and 15% of the chlorine will volatilize. These percentages will increase with increasing temperature to values of approximately 40% alkali release and 80% chlorine release at 740 °C (1364 °F).

Table 3. Analysis of original biomass samples (unashed).

Element	Units	Detection Limit	SWITCH GRASS	APPLE LEAVES	certified values	PINE NEEDLES	certified values
Au	PPB	0.1	< 0.1	0.4	[0.001]	1.4	
Ag	PPM	0.3	< 0.3	< 0.3		< 0.3	
As	PPM	0.01	0.1	0.17	0.038	0.19	0.21
Ba	PPM	5	20	50	49	6	
Br	PPM	0.01	12	2.1	[1.8]	6.8	[9]
Ca	%	0.01	0.28	1.53		0.42	0.41
Cd*	PPM		<0.5	<0.5	13	<0.5	<0.5
Cl	PPM		681	605	579	465	
Co	PPM	0.1	0.1	0.1	[0.09]	0.2	
Cr	PPM	0.3	1.8	1.1	[0.3]	2.7	
Cs	PPM	0.05	< 0.05	< 0.05		0.12	
Fe	%	0	0.012	0.008	0.0083	0.021	0.020
Hf	PPM	0.05	< 0.05	0.05		< 0.05	
Hg*	PPB	1	13	106	44	39	150
Hg	PPM	0.05	< 0.05	< 0.05	0.044	0.12	0.15
Ir	PPB	0.1	< 0.1	< 0.1		< 0.1	
K	%	0	0.384	1.62		0.34	
Mo	PPM	0.05	0.3	< 0.08	0.094	< 0.05	
Na	PPM	0.5	16.3	24.4	24.4	36	
Ni	PPM	2	< 2	< 2	0.91	< 2	[3.5]
Pb*	PPM		0	7	470	3	10.8
Rb	PPM	1	6	10	10.2	11	
S	%		0.09	0.15		0.15	
Sb	PPM	0	0.007	0.02	[<0.2]	0.16	
Sc	PPM	0.01	0.02	0.03		0.03	
Se	PPM	0.1	< 0.1	< 0.1	0.05	< 0.1	
Sr	PPM	10	17	< 10	25	30	4.8
Ta	PPM	0.05	< 0.05	< 0.05		< 0.05	
Th	PPM	0.1	< 0.1	< 0.1		< 0.1	0.037
U	PPM	0.01	< 0.01	< 0.01	[0.006]	0.01	0.02
W	PPM	0.05	< 0.05	< 0.05	[0.007]	< 0.05	
Zn*	PPM		10	26	12.5	26	
Zn	PPM	2	14	11	12.5	59	
La	PPM	0.01	0.12	25	[20]	0.2	[0.2]
Ce	PPM	0.1	0.1	3		0.3	
Nd	PPM	0.3	< 0.3	17		< 0.3	
Sm	PPM	0	0.012	2.8		0.023	
Eu	PPM	0.05	< 0.05	0.23		< 0.05	
Tb	PPM	0.1	< 0.1	0.3		< 0.1	
Yb	PPM	0	0.013	0.212		< 0.005	
Lu	PPM		< 0.001	0.024		< 0.001	

Notes: Bracketed values of the standards are not certified.

Analysis performed by neutron activation for most elements

* - alternate analysis used for determination

Table 4. Analysis of ashed biomass samples.

Element	Units	Detection	SWITCH		certified values
		Limit	GRASS	FLYASH	
% ash in original sample			5.494		
Au	PPB	5	<5	<5	
Ag	PPM	2	<2	<2	
As	PPM	0.5	1.5	145	145
Ba	PPM	10	288	1400	1500
Br	PPM	1	77	<1	
Ca	%	0.2	4.9	3.8	1.11
Co	PPM	1	3	46	46
Cr	PPM	1	30	200	196
Cs	PPM	0.5	0.6	11	11
Fe	%	0.05	0.22	9.69	9.4
Hf	PPM	0.5	0.6	9.7	[8]
Hg	PPM	1	<1	<1	0.16
Ir	PPB	2	<2	<2	
K	%	0.05	6.16	2.6	1.88
Mo	PPM	2	6	28	[29]
Na	PPM	10	470	1700	1700
Ni	PPM	50	<50	150	127
Rb	PPM	5	95	130	131
Sb	PPM	0.1	0.2	6.6	[6.8]
Sc	PPM	0.1	0.7	43	[40]
Se	PPM	2	<2	11	10.3
Sr	PPM	0	<300	870	830
Ta	PPM	300	<1	2	[2]
Th	PPM	0.5	0.6	25	24.7
U	PPM	0.1	<0.1	10	10.2
W	PPM	0.1	<1	<1	[5.7]
Zn	PPM	1	300	280	220
La	PPM	20	2	88	[84]
Ce	PPM	0.1	4	193	[180]
Nd	PPM	3	<5	81	[74]
Sm	PPM	5	0	17	[17]
Eu	PPM	0.1	0	4	4
Tb	PPM	0.01	<0.5	2.9	[2.5]
Yb	PPM	0.5	0.2	9.7	[7.4]
Lu	PPM		<0.05	1.48	[1.12]

Notes: Missing elements if interest include chlorine (Cl), lead (Pb), and sulfur (S)
 Ashing was performed at 480 C
 Analysis performed by neutron activation

Biomass Gasification Testing

• Switchgrass Gasification

The goal of feeding and gasifying switchgrass as a result of this project has been achieved. Several methods of handling and injection were tried, as discussed above. Variations of these systems include injection augers operating at different speeds, different airlocks, and the use of a plug maker for switchgrass injection with compaction. Each of these methods has advantages and disadvantages. Additionally, feedstock preparation is an essential variable to a feed system.

Originally we were trying to do as little preparation as possible. Basically this involved shredding the switchgrass bales in a tub grinder. The result was varying lengths of switchgrass from < 0.25" up to 8". Ultimately this resulted in difficult to feed material that hung up in the system and bunched easily. Ideally the switchgrass would be chopped to < 1 inch. Chopping is the preferred method of preparation compared to hammer milling. Chopping is preferred because clean cuts to the switchgrass stalk increase bulk density and minimize bridging potential. Processing with a hammer mill will reduce the size but results in the ends of the switchgrass stalk being frayed (much like a broom end), inhibiting flow characteristics and decreasing bulk density. The approach chosen involved processing the switchgrass with a hammer mill as this equipment was readily available. The hammer mill available to us is mounted in a farm-scale portable mixer-grinder. A one-inch screen resulted in 95% of the switchgrass having a length less than one inch. The resulting bulk density of the product was 6-8 lb/ft³.

The switchgrass available to us was baled in the late summer of 1996. At that time the moisture content was ~24%. The high moisture has meant the bales do not store well. In many cases the bales had a wet inner core with some of the grass slightly fermented. Mold was very evident in the bales as they were being processed. Even though the bales were covered, the outdoor storage resulted in an average moisture content of 30-35%. The high moisture content forced us to utilize the processed switchgrass within the next 48 hours to prevent overheating and potentially ignition of the material.

Two successful tests were performed using the second generation feed system. The first test lasted only one hour as we had prepared approximately 440 pounds of switchgrass. The second test lasted approximately two and a half hours. Producer gas samples were taken and analyzed. Tar and moisture content data are not available from this test.

Approximately 1200 pounds of switchgrass was prepared for the second test. The reactor was operated with an air injection rate of ~ 110 scfm. Approximately 450 lb/hr of fuel was injected to achieve an equivalence ratio of 0.28. The high moisture content of the fuel resulted in non-uniform feeding of the switchgrass into the reactor. Therefore, slugs of material would be injected in a short time period resulting in a large gas production. This uneven gasification resulted in varying gas composition and high char carry over from the bed.

Table 5 shows the gas composition from five samples taken over the course of the experiment. The gas concentrations were determined using a gas chromatograph (GC) and a Fourier transform infrared spectrometer (FTIR). The GC is calibrated for nitrogen, hydrogen, carbon monoxide, methane, and carbon dioxide while the FTIR is calibrated for carbon monoxide, methane, carbon dioxide, and ethylene. The FTIR is able to detect acetylene and ethane but it has not yet been calibrated for these gases. It is unable to detect nitrogen, hydrogen, and oxygen because these gases are optically inactive. The gas is reported on a dry, tar-free basis.

The higher heating value of the producer gas varied between 117-163 Btu/scf with an average value of 144 Btu/scf. This is respectable considering the uneven feed of fuel and the high carryover of char. The carbon conversion for this test is estimated at 72%. This is determined by doing a rough mass balance on the system. We fed approximately 1200 pounds of switchgrass which on a dry basis is about 840 pounds (assuming 30% moisture). Switchgrass is

approximately 47% carbon (by ultimate analysis) equating to a carbon input to the system of approximately 400 pounds.

Approximately 150 pounds of particulates was collected with the cyclones. Assuming most of this is carbon (75%) this gives an approximate carbon conversion 72%. As mentioned previously, the high char carryover from the bed is probably due to the uneven feeding and gas production. In fact, small fibrous particles were visible in the cyclone catch which is clear evidence of inadequate particle residence time. Several measures may be taken to increase char conversion including a uniform fuel feed, decreasing the superficial velocity via air flow rate, and reinjection of elutriated solids.

Table 5. Gas composition and heating value for switchgrass gasification test.

Sample #	N ₂	H ₂	CO	CH ₄	CO ₂	C ₂ H ₂ *	C ₂ H ₄	C ₂ H ₆	Total	HHV (Btu/scf)
1	56.18	3.68	12.55	3.53	15.33	0.20	1.60	0.00	93.07	117
2	60.18	5.61	17.06	5.16	19.71	0.20	2.13	0.00	110.05	163
3	61.40	4.75	14.83	4.37	20.30	0.20	1.96	0.00	107.81	142
4	54.68	3.93	16.49	4.85	17.36	0.20	1.92	0.00	99.43	149
5	53.88	3.25	16.47	4.94	17.52	0.20	1.99	0.00	98.25	149
Avg.	57.26	4.24	15.48	4.57	18.04	0.20	1.92	0.00	101.72	144

* - estimated value (detected but not quantified)

- Trace Contaminants in Fuel Gas

Detection and quantification of contaminants in the fuel gas is not a trivial task. Many factors affect the chemistry of trace contaminants further complicating the issue. Gas sampling techniques must be carefully planned and performed meticulously to ensure proper quantification of a given contaminant. Initial contaminant levels in the feedstock, reactor temperature, use of steam, fluidized bed media, sample line material, sample line temperature, and sample collection techniques are important factors in the levels of contaminants.

High levels of contaminants are likely to result in high vapor phase concentrations of the contaminants. However, as discussed in the *Feedstock Characterization* section above, reactor temperature plays a crucial role in how much of the contaminant is released. Lower reactor temperature result in lower release rates. Therefore it may be possible to control, to some extent, the percentage of contaminants released. Furthermore, choice of fluidized bed media may also play a role in contaminant release. It has been suggested that lime and possibly limestone sorb alkali to a certain extent. The use of steam may also change the form of the contaminant in the gas stream. Alkali which may normally be released as a chloride in the absence of steam may instead be released as a hydroxide and the chlorine instead as hydrogen chloride. All these species will exist in greater or lesser extents depending on the thermodynamic equilibrium. Because these species will react or even condense depending on the temperature, careful consideration of the sample system is due. Vapor phase alkali will condense on sample line walls if the sample line temperature drops below 600 °C (1112 °F).

Biomass Gasification/Fuel Cell System Analysis

This section addresses the use of a fuel cell power plant operating on fuel from biomass gasification. Evaluation is based on the Iowa State University (ISU) gasifier and the direct carbonate fuel cell power plant presently under development by Energy Research Corporation for utility application. The evaluation includes a description and performance of the commercial fuel cell power plant operation on natural gas fuel. The performance of the fuel cell power plant is then presented for operation on fuel from the ISU air blown gasifier on seed corn and switchgrass. Lastly the performance of the fuel cell power plant is presented for operation on fuel from an ISU latent heat ballasted gasifier. In addition the expected performance of fuel cell power plants with a steam bottoming cycle and projected economics is also presented.

- Direct carbonate fuel cell power plant

The Commercial fuel cell power plant presently under development at ERC for utility application has a nominal 2.5 MW rating while operating on natural gas. The net LHV efficiency of the power plant is 53%. The power plant, shown in Figure 7, shown in the background section, occupies about 4500 ft². The plant includes two stack modules each containing 4 fuel cell stacks, thermal management equipment and electrical equipment to convert the DC to 60 Hz AC and step up the voltage to the distribution grid requirement.

A simplified system schematic of the commercial direct fuel cell power plant process is shown in Figure 8 along with process conditions at the interfaces. In the commercial natural gas power plant 296 SCFM of natural gas is compressed and flows through a cleanup bed, which removes sulfur and chlorides. The fuel is then mixed with steam and flows to a pre-converter, which removes the small amounts of heavier hydrocarbons in the natural gas. The fuel is then heated and flows to the fuel cell stacks. In the direct carbonate fuel cell stacks the fuel is internally reformed, forming hydrogen, which is used by the fuel cell anodes to generate DC current. A fraction of the converted fuel, which is not reacted in the cell stacks flows to a catalytic oxidizer where it is consumed with process air. The stream from the catalytic oxidizer then flows to the fuel cell cathodes supplying both the oxygen and carbon dioxide, which are used to complete the carbonate fuel cell electrochemical reaction. Exhaust from the fuel cell, which operates at about 1200 °F, flows through the fuel processing heat exchangers and exits the plant at a temperature over 800 °F. The direct carbonate fuel cell power plant has exceptionally high (53%) efficiency because all the energy required to produce steam and to convert the natural gas fuel to hydrogen by steam reforming is provided by the waste heat generated by the fuel cell. The high exhaust temperature also offers the opportunity to add a steam bottoming cycle, which would generate an additional 446 kW and raise the plant efficiency to 61.4%.

- Direct carbonate fuel cells on gasified seed corn

Fuel from an ISU air blown gasifier operating on seed corn has a heating value of 108 Btu/scf (LHV) compared to natural gas, which has a heating value of 933 Btu/scf. Analysis of the ERC commercial power plant was also conducted to evaluate operation on this lower heating value fuel. Material and energy balances were established as well as evaluation of system pressure losses and resulting process pressures. These studies determined that the lower fuel

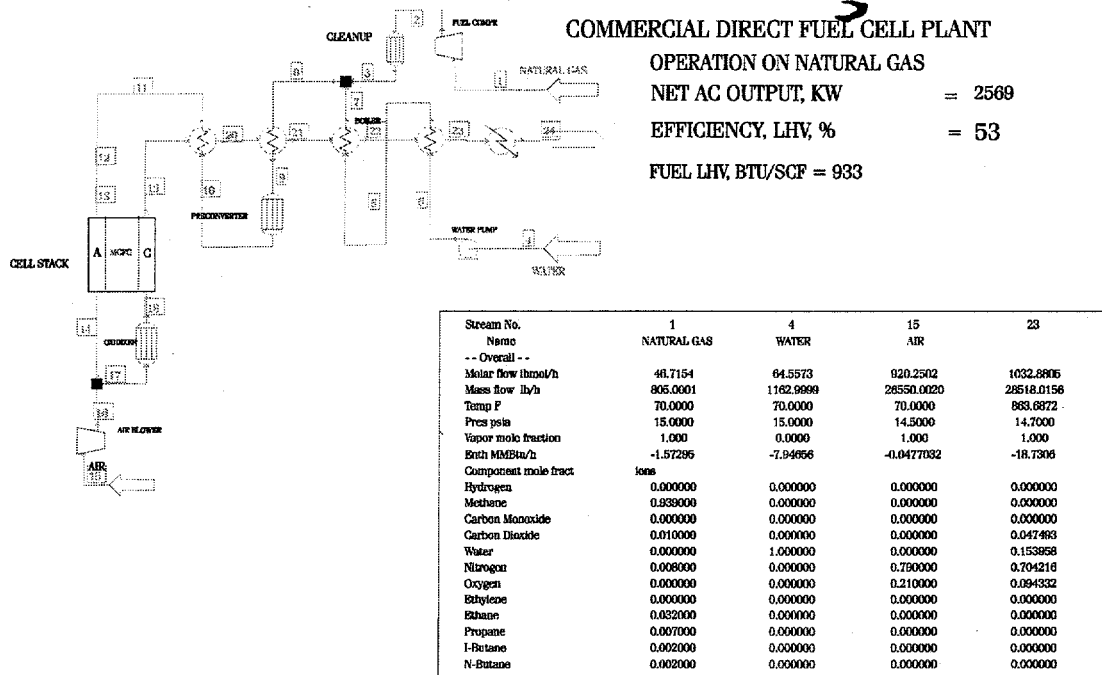

3MWO0M0B2

RAS 8/28/98

Figure 8. ERC Commercial Natural Gas Direct Fuel Cell System – Process Flow Diagram

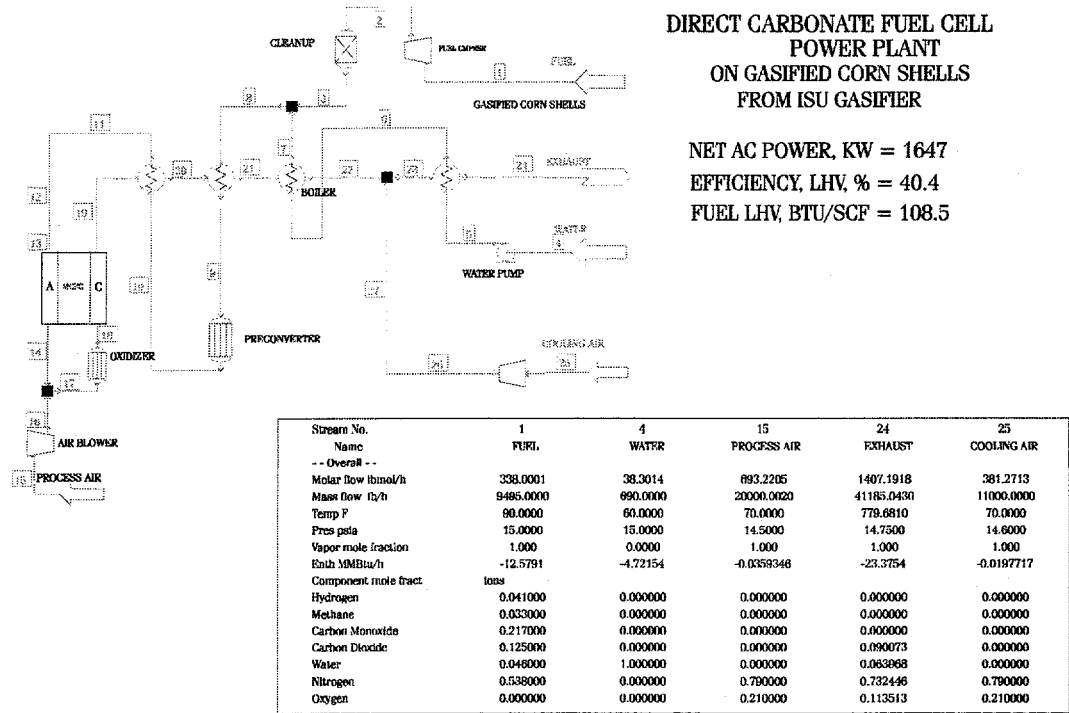

3MWS0S0B2

RAS 8/31/98

Figure 9. Direct carbonate fuel cell system operating on gasified seed corn from an ISU air blown gasifier.

heating value would result in higher gas flow through the ERC commercial natural gas power plant. Due to current design constraints based on natural gas operation, operation on a low BTU gas would require derating the power plant. As a result the power plant is derated to 1647 kW at which power level the gas flow rates are acceptable. The performance and process conditions at the power plant interfaces are shown in Figure 9. Power plant efficiency is 40.7% on the gasified seed corn. Modifications to the standard commercial fuel cell power plant include; a fuel gas compressor capable of delivering 2138 SCFM, a process to cleanup sulfur and chlorides consistent with impurities from the gasifier, a modified pre-converter capable of methanating the gasified fuel composition and a cooling blower required to accommodate cooling requirements of the fuel processor.

- Direct carbonate fuel cells on gasified switchgrass

Fuel from an ISU air blown gasifier operating on switchgrass has a heating value of 124 Btu/scf compared to natural gas, which has a heating value of 933 Btu/scf. Analysis of the ERC commercial power plant was conducted to evaluate operation on this lower heating value fuel. Material and energy balances were established as well as evaluation of system pressure losses and resulting process pressures. As in the case of corn shell feedstock the lower fuel heating value would result in higher gas flow through the ERC commercial power plant. As a result the power plant is derated to 1690 kW at which power level the gas flow rates are acceptable. The performance and process conditions at the power plant interfaces are shown in Figure 10.

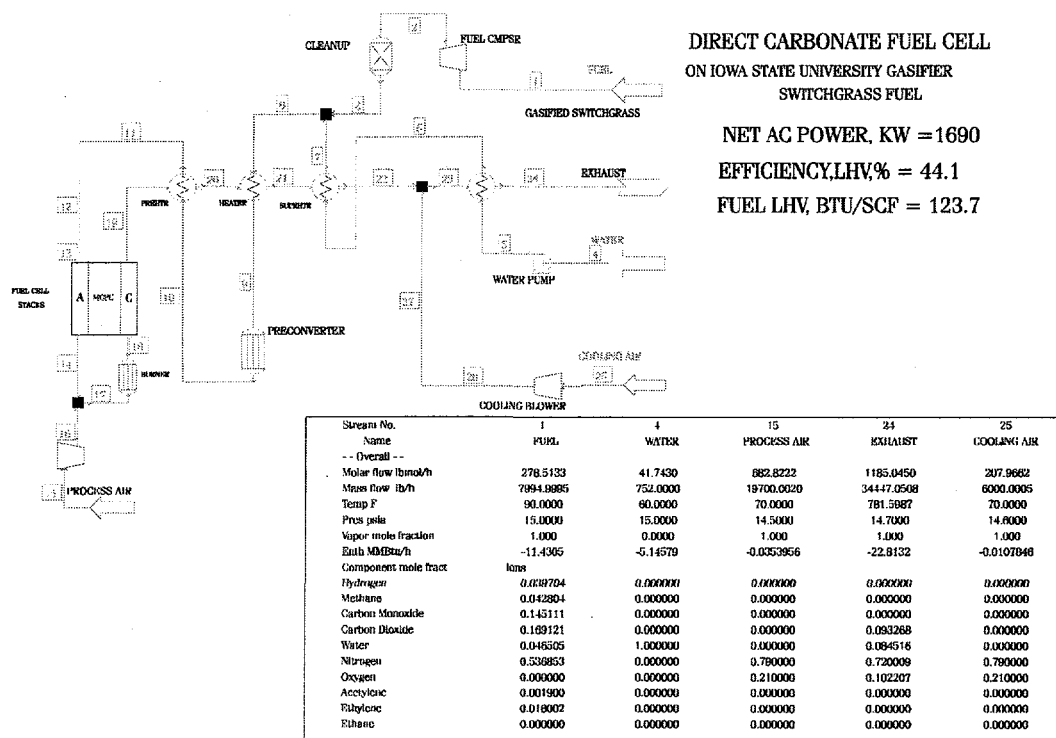

3MWISEG2DB2

RAS 5/2/98

Figure 10. Direct carbonate fuel cell system for operation on gasified switchgrass from an ISU air blown gasifier

Power plant efficiency is 44.1% on the gasified switch grass. Modifications to the standard commercial fuel cell power plant include; a gas compressor capable of delivering 1761 scfm, a process to cleanup sulfur and chlorides consistent with impurities from the gasifier, a modified pre-converter capable of methanating the gasified fuel composition and a cooling blower required to accommodate cooling requirements of the fuel processor. The 700°F exhaust temperature offers the opportunity to add a steam bottoming cycle, which would generate an additional 314 kW and raise the plant efficiency to 52.3%.

Since the fuel cell power plants are modular they can be grouped to match the fuel delivery of the ISU air blown gasifier. An example of this is shown in Figure 11. The fuel from the air blown ISU gasifier in MMSCFD (million standard cubic feet per day) is shown as a function of the number of fuel cell modules nominally rated at 2 MW. Also shown is the net AC power output of the power plant as a function of the number of fuel cell modules for installations with and without a steam bottoming cycle.

DIRECT FUEL CELL POWER PLANTS ON GASIFIED SWITCHGRASS FROM AIR BLOWN ISU GASIFIER

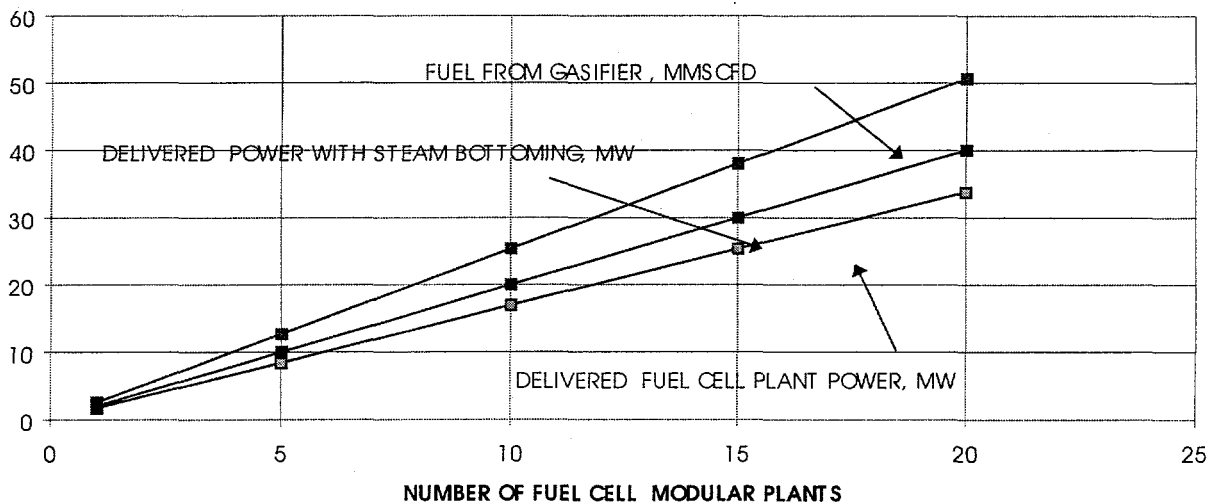
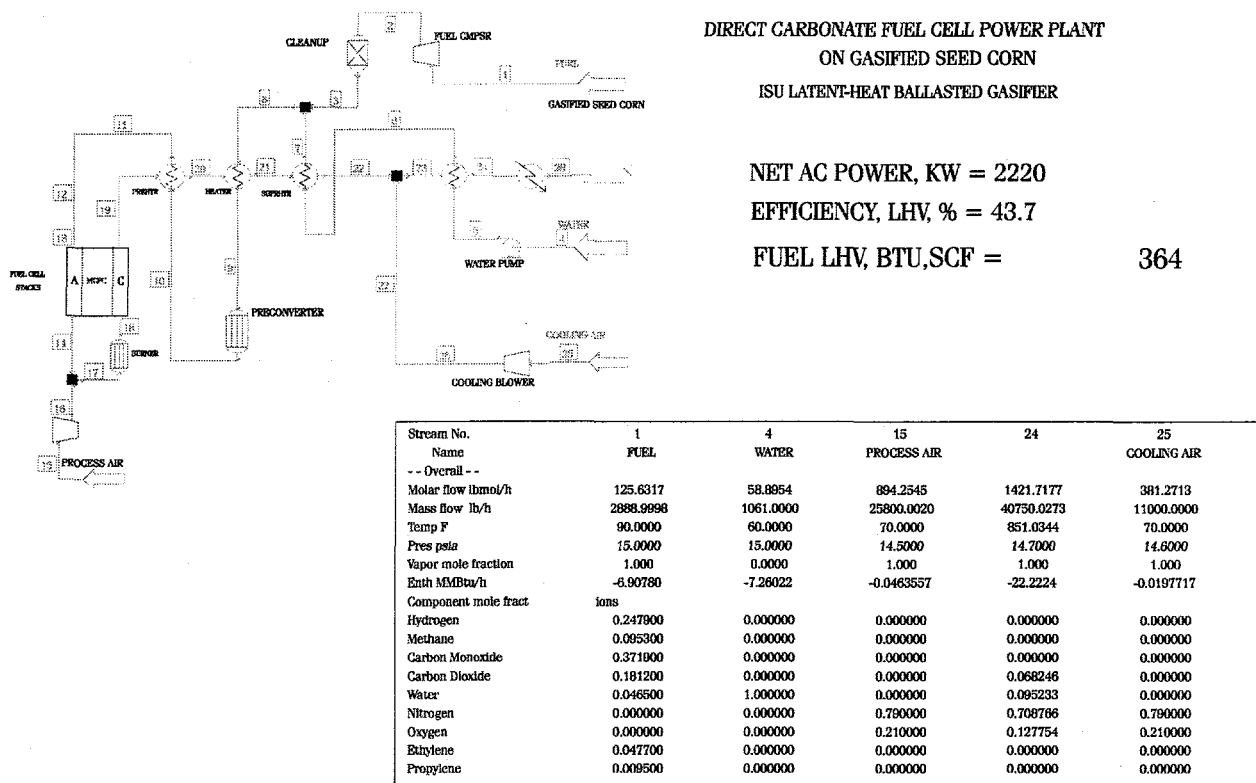

Figure 11. Power output and fuel gas requirement for direct fuel cell power plants operating on gasified switch-grass using the ISU air blown gasifier.

- Direct carbonate fuel cells on fuel from an ISU latent heat ballasted gasifier

Fuel from an ISU latent-heat ballasted gasifier operating on seed corn has a heating value of 364 Btu/scf compared the air blown gasifier fuel which has a heating value of 124 Btu/scf. Analysis of the ERC commercial power plant was conducted to evaluate operation on this ballasted gasifier fuel. Material and energy balances were established as well as evaluation of system pressure losses and resulting process pressures. Because of the heating value, the commercial ERC fuel cell power plant can produce 2220 kW compared to 2569 kW on natural gas. This represents only a 13.6% power derating. The performance and process conditions at the power plant interfaces are shown in Figure 12. Power plant efficiency is 43.7 % on the gasified

switchgrass. Modifications to the standard commercial fuel cell power plant would include; a fuel gas compressor capable of delivering 795 scfm, a process to cleanup sulfur and chlorides consistent with impurities from the gasifier, a modified pre-converter capable of methanating the gasified fuel composition and a cooling blower required to accommodate cooling requirements of the fuel processor. The 851°F exhaust temperature offers the opportunity to add a steam bottoming cycle, which would generate an additional 400 kW and raise the plant efficiency to 51.6%.



3MWISSCDB2

RAS 9/2/98

Figure 12. Direct carbonate fuel cell system for operation on gasified seed corn from an ISU latent heat ballasted gasifier

Since the fuel cells power plants are modular they can be grouped to match the fuel delivery of the ISU latent heat ballasted gasifier. An example of this is shown in Figure 13. The fuel from the ISU latent heat ballasted gasifier in MMSCFD is shown as a function of the number of fuel cell modules. Also shown is the net AC power output of the power plant as a function of the number of fuel cell modules for installations with and without a steam bottoming cycle.

Thermal integration of the gasifier with the fuel cell power plant

In the study results presented so far there was no thermal integration of the fuel cell power plant with the gasifier. The fuel cell power plant operates on fuel from the gasifier and exhausts hot gas to the environment. There are a number of opportunities for thermal integration of the fuel

cell power plant with the gasifier. The most straightforward form of thermal integration is the use of the 800 F exhaust from the fuel cell power plant for drying the raw switch grass or other biomass fuel. Preheating of the gasifier air can also be accomplished by heat exchange with the 1180°F cathode exhaust stream. This requires a large high temperature heat exchanger. In larger installations an effective approach is the use of a steam bottoming cycle which operates on the combined exhaust from the gasifier and the 800°F fuel cell power plant exhaust.

Another possibility for thermal integration is to pipe the depleted vent gas from the fuel cell anodes, which has hydrogen and CO, to supplement fuel to the burner in the indirect gasifier. In turn the gasifier would deliver its burner exhaust to the fuel cell power plant where the CO₂ could be mixed with additional air for the fuel cell cathodes. However this alternative may require special gasifier burner exhaust cleanup to avoid contamination of the fuel cell cathodes. A concern with this approach is the high temperature piping for moving gases back and forth between the gasifier and the fuel cell power plant and the probable requirement for additional blowers to accommodate piping pressure losses within process pressure limitations.

DIRECT FUEL CELL POWER PLANTS ON GASIFIED SEED CORN FROM LATENT-HEAT BALLASTED ISU GASIFIER

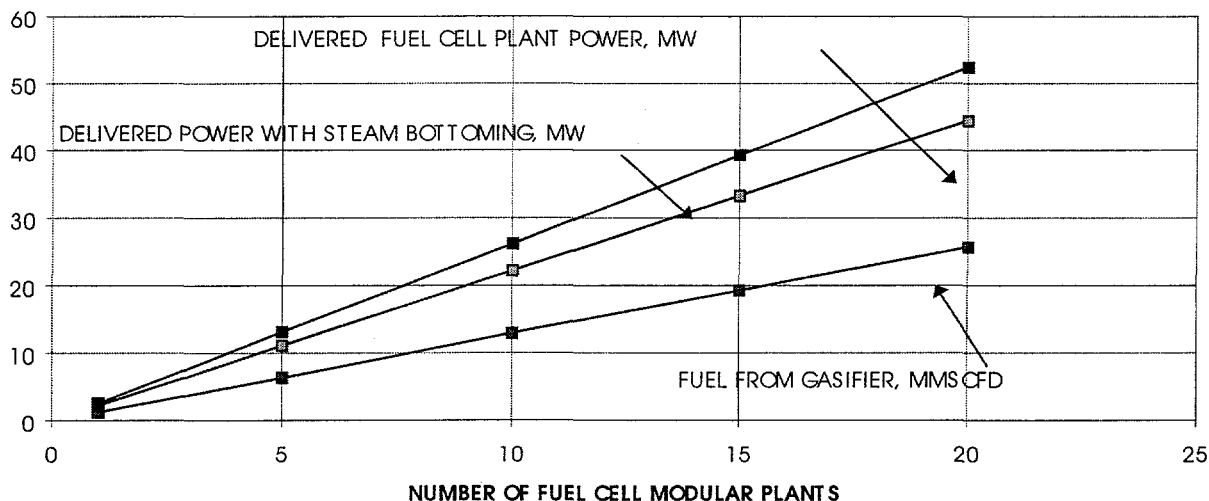

Figure 13. Grouping ERC modular fuel cells to ISU latent heat ballasted gasifier.

ECONOMICS OF BIOMASS GASIFICATION/FUEL CELL SYSTEMS

The commercial direct carbonate fuel cell power plant presently under development, which delivers 2.57 MW on natural gas, is expected in commercial production, to have a capital cost of about \$3.5 million. This results in a specific cost of \$1370/kW. The additions to the power plant for operation on gasified switch grass fuel from an air blown ISU gasifier with a lower heating value of only 124 Btu /scf is expected to add about \$200,000 in modifications to the standard plant. Thus for operation on gasified switch grass the fuel cell plant cost would be \$3.7 million

for a 1690 kW net AC output resulting in a specific cost of \$2190/kW. The higher cost is due primarily to the derating of the plant on low Btu fuel.

The additions to the power plant for operation on gasified seed corn fuel from a latent heat ballasted ISU gasifier with a lower heating value of 364 Btu/scf, are also expected to add about \$200,000 in modifications to the standard plant. Thus fuel cell plant cost would be \$3.7 million but the output would be a net 2200 kW resulting in a specific cost of \$1680/kW. In low power installations the addition of a steam bottoming cycle is not expected to be economically viable. However for large installations with a fuel cell power output of 20 MW, a 4 MW steam bottoming cycle In low power installations the addition of a steam bottoming cycle is not expected to be economically viable. However for large installations with a fuel cell power output of 20 MW, a 4 MW steam bottoming cycle addition to the fuel cell power plant would be more attractive at a specific cost approaching \$1000/kW. The addition of waste heat from the gasifier could make a steam bottoming cycle more viable for smaller power plant size.

CONCLUSIONS

The experimental and analytical objectives of this project were achieved. Gasification of switchgrass at the pilot-scale (5 ton per day) was successful. Moving chopped switchgrass from a hopper to the reaction chamber proved to be the most challenging aspect of the gasification activities. Bridging of switchgrass in hoppers and chutes and back flow of hot gases to the fuel hopper was very common and difficult to control until late in the project. However, a successful feeder system was devised that overcame fuel bridging and gas back flow. Conventional, air-blown gasification of switchgrass yielded product gas with heating value ranging from 105 Btu/scf to 145 Btu/scf. Tests with a latent-heat ballast installed in the gasifier achieved gas heating values approaching 450 Btu/scf.

Fuel from an ISU air blown gasifier operating on seed corn would require a carbonate fuel cell power plant to be derated to 1647 kW. Power plant efficiency is 40.4% on the gasified seed corn. Fuel from an ISU air blown gasifier operating on switchgrass would require a carbonate fuel cell power plant to be derated to 1690 kW. Power plant efficiency is 44.1% on the gasified switch grass. Operation on gasified switch grass the fuel cell plant cost would be \$3.7 million for a 1690 kW net AC output resulting in a specific cost of \$2190/kW. Fuel from a latent-heat ballasted gasifier operating on seed corn would have to be derated by 13.6%. Power plant efficiency would be 43.7 % on the gasified switch grass.

A number of issues concerning integration of subsystems have yet to be addressed. A feed system that can handle a variety of chopped biomass has been developed that shows promise but has not been adequately tested in long-term gasification trials. Only recently has adequate equipment been obtained for characterizing contaminants in the product gas that can poison fuel cell catalysts. A gas clean-up system that can remove these contaminants has yet to be selected. Additional effort is required to address these issues and to pursue the potential of biomass gasification/fuel cell power generation.

REFERENCES

1. Swan, D.H., et al., "PEM Fuel Cell Characterization for EV Applications", SAE Paper 940296, Detroit, 1994.
2. Singhal S.C., "Advances in Tubular Solid Oxide Fuel Cell Technology", 1996 Fuel Cell Seminar, p. 28, Orlando, 1996.
3. Baker, B.S., et. al., "Proceedings of the American Power Conference", Vol. 56-I, p. 179, Chicago, 1994.
4. Baker, B.S., "Fuel Cell Systems for Utilities", presented at the American Power Conference, April 1997.