



⑫

EUROPEAN PATENT APPLICATION

⑰ Application number : **91307363.1**

⑸ Int. Cl.⁵ : **C10G 65/04**

⑱ Date of filing : **09.08.91**

⑳ Priority : **14.08.90 US 567033**

㉓ Date of publication of application :
19.02.92 Bulletin 92/08

㉔ Designated Contracting States :
FR GB IT

㉕ Applicant : **EXXON RESEARCH AND
ENGINEERING COMPANY**
P.O.Box 390, 180 Park Avenue
Florham Park, New Jersey 07932 (US)

㉖ Inventor : **Boucher, Heather Alexis**
W51-1500 Venetian Blvd.
Point Edward, Ontario N7T 7W4 (CA)
Inventor : **Macdonald, John Mackillop**
152, Norman Street
Sarnia, Ontario N7T 6V7 (CA)

㉗ Representative : **Somers, Harold Arnold et al**
ESSO Engineering (Europe) Ltd. Patents &
Licences Mailpoint 72 Esso House Ermyn Way
Leatherhead, Surrey KT22 8XE (GB)

⑸④ **Method of hydrotreating heavy hydroisomerate fractionator bottoms to produce quality light oil upon subsequent re-fractionation.**

⑸⑦ The heavy bottoms material (13) boiling above about 580°C, obtained from the fractionation (7) of the isomerate (6) produced by the hydroisomerization (4) of heavy waxes (1) such as Bright Stock slack wax and Fischer-Tropsch synthetic wax, is converted into a high quality light oil (11) by severe hydrotreating (14), followed by re-fractionation (7) in either a dedicated fractionator or by recycle to the isomerate fractionator (7).

FIG. 1

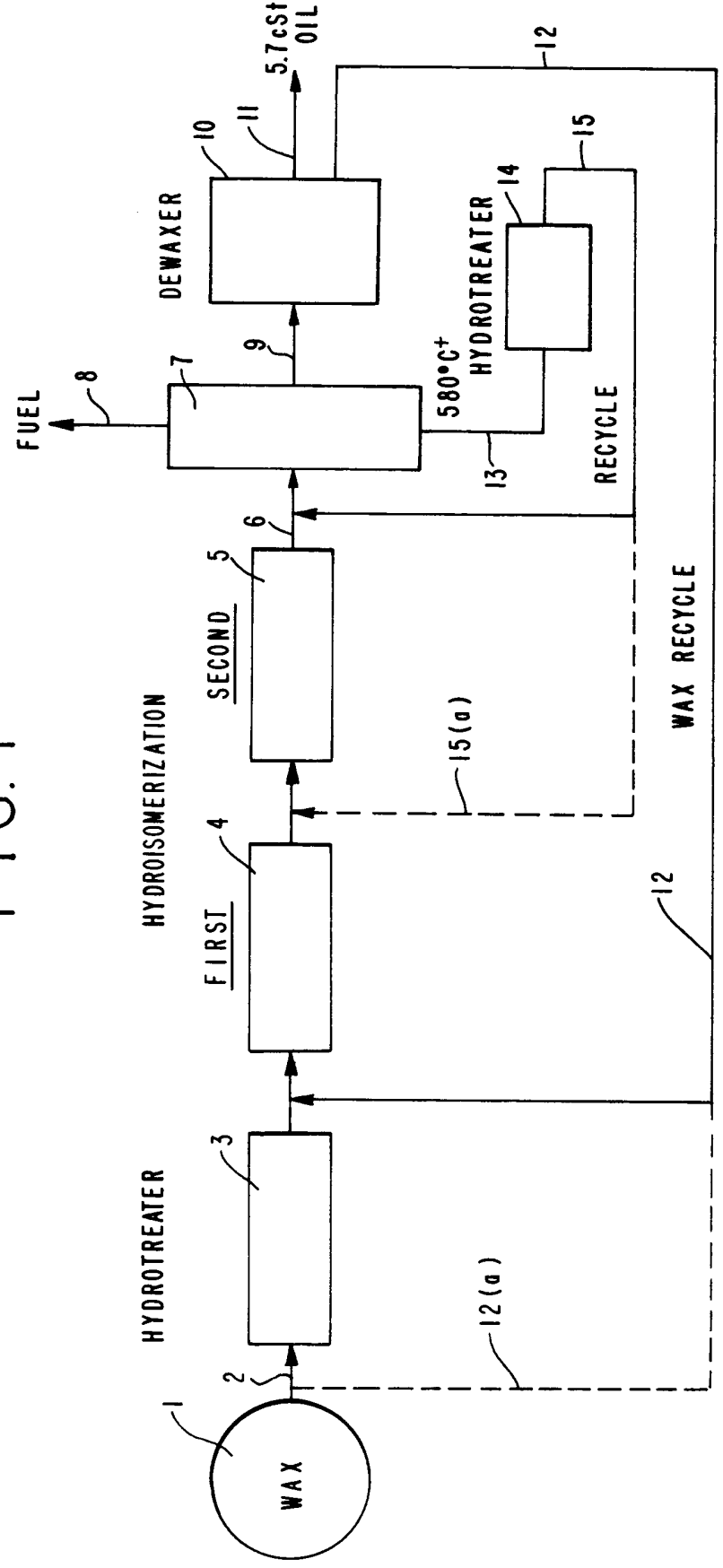

Brief Description of the Invention

5 Fractionator tower bottoms material boiling in the 580+°C range recovered by the fractionation of isomerate produced by the hydroisomerization of heavy waxes such as Bright Stock Slack wax or Fischer-Tropsch synthetic wax is converted in good yield into a quality light oil by the practice of a severe hydrotreating step followed by refractionation. The severely hydrotreated bottoms may be dewaxed either prior to or after the refractionation step.

Description of the Figure

10

The figure presents a schematic of a preferred embodiment of the present invention.

Background of the Invention

15 The hydroisomerization of wax, be it natural wax, such as slack wax, or synthetic waxes such as Fischer-Tropsch wax, into lube oil involves, in addition to any deoiling and/or hydrotreating deemed necessary and/or desirable and hydroisomerization, the further steps of fractionation of the isomerate product into various fractions, preceded or followed by any needed dewaxing steps.

20 The fractionation of the total hydroisomerate product will yield a light fraction boiling below about 330-370°C, a heart cut fraction boiling between about 330-370 and 580-600°C and a heavy residue fraction boiling above about 580-600°C (hereinafter referred to as the "Fractionator Tower Bottoms"). The heart cut fraction boiling between 330-370°C to 580-600°C is dewaxed by any conventional solvent dewaxing process employing, e.g. methylethylketone (MEK), methylisobutyl ketone (MIBK), and mixtures thereof, to yield a high viscosity index lube oil base stock or blending stock. The recovered wax will be recycled to the isomerization unit after having been subjected to any needed hydrotreating to remove dewaxing solvent contaminants. In general, the heavy residue boiling above 580-600°C will also be recycled to the hydroisomerization unit because of the high concentration of wax contained therein. This recycle stream may be first deoiled and/or hydrotreated as needed to protect the hydroisomerization catalyst from contamination and possible deactivation. While this recycle of very high boiling isomerate product to the isomerization zone presents one way of dealing with and utilizing said material, the yield of additional desirable oil by the further isomerization of this fraction is low because molecular weight reduction is inefficient and insufficient.

25

It would, therefore, be a desirable advance if the fractionator tower bottoms could be processed to advantageously recover increased yields of desirable oil product.

Description of the Invention

35

40 It has been discovered that improved yields of superior quality light lubricating oil can be recovered from the 580-600+°C fractionation tower bottoms, when this fraction is subjected to severe hydrotreating followed by refractionation. This severe hydrotreating step reduces the average molecular weight of the fractionator tower bottoms, leading to a reduction in its viscosity and average boiling point. This distinguishes this step from the mild hydrotreating step carried out with the fresh slack wax feed, wherein very little molecular weight reduction takes place. In mild hydrotreating, the primary aim is the removal of heteroatoms, with very little hydrocarbon conversion taking place.

45 The oil produced by the practice of this process is characterized by having a lower viscosity than oil produced by hydroisomerization of said fraction, and by having a higher viscosity index. The product from the severe hydrotreating step can be dewaxed prior to its fractionation or the heart cut fraction boiling between about 330°C and 580°C to 600°C can be dewaxed after the fractionation step.

50 The heavy bottoms fraction is subjected to hydrotreating under severe conditions including a temperature in the range 300 to 500°C, preferably 350 to 450°C, a pressure in the range 500 to 5000 psig, preferably 1000 to 2500 psig, a hydrogen gas treat rate of 250 to 5000 SCF H₂/bbl feed, preferably 1000 to 3000 SCF H₂/bbl feed and a space velocity of 0.1 to 10.0 v/v/hr, preferably 0.25 to 2.0 v/v/hr. The catalyst used in this severe hydrotreating step can be any of the typical hydrotreating catalysts which include the metals, oxides or sulfides of Group VIB or non-noble Group VIII on a refractory metal oxide support such as alumina or silica/alumina. Preferred catalysts include Co/Mo on alumina and/or, Ni/Mo on alumina or silica/alumina.

55 The present invention will usually be practiced as part of a complete wax isomerization to oil process.

The wax which is isomerized may come from any of a number of sources. Synthetic waxes from Fischer-Tropsch processes may be used, as may be waxes recovered from the solvent or autorefrigerative dewaxing of conventional hydrocarbon oils as well as mixtures of these waxes. Waxes from dewaxing conventional hyd-

rocarbon oils are commonly called slack waxes and usually contain an appreciable amount of oil. The oil content of these slack waxes can range anywhere from 0 to 45% or more, usually 5 to 30% oil. For the purposes of this application, the heavy waxes recovered from the dewaxing of Bright Stock and the heavy Fischer-Tropsch waxes are the feeds of choice.

5 Hydroisomerization is performed over any of the standard hydroisomerization catalysts which contain a hydrogenation metal selected from Group VIB and Group VIII and mixtures thereof, preferably the Group VIII metals, more preferably the noble Group VIII metals, most preferably platinum. Metal loading ranges between 0.1 to 5.0 wt% metal, preferably 0.1 to 1.0 wt% metal, most preferably 0.2 to 0.6 wt% metal.

10 The hydrogenation metal component is supported on a halogenated refractory inorganic metal oxide support, preferably alumina or silica-alumina, most preferably the transition aluminas, e.g., gamma alumina. The halogen is usually chlorine or fluorine or mixture thereof, preferably fluorine, net halogen content in the range 0.5 to 10 wt%, preferably 1 to 8 wt%.

15 Isomerization is conducted under conditions of temperature between about 250 to 400°C, preferably 270-360°C, pressures of 500 to 3000 psi H₂, preferably 1000-1500 psi H₂, hydrogen gas rates of 1000 to 10,000 SCF/bbl feed, and a space velocity in the range 0.1-10 v/v/hr, preferably 1-2 v/v/hr.

Preferred catalysts are the subject of U.S. Patent 4,959,337, U.S. Patent 4,906,601 and U.S. Patent 4,900,707.

The use of these catalysts for the production of a lube oil base stock or blending stock by the isomerization of wax is the subject of U.S. Patent 4,929,795, U.S. Patent 4,923,588 and U.S. Patent 4,937,399, respectively.

20 The catalyst of USP 4,959,337, contains a hydrogenation metal component which is a Group VIII metal or mixture thereof, preferably noble Group VIII metal, most preferably platinum on a fluorided alumina or material containing alumina, preferably alumina or material consisting predominantly (i.e. >50%) of alumina, most preferably gamma or eta alumina wherein said catalyst in its as introduced to waxy feed form is characterized by possessing (1) a hydrate level of 60 or less, preferably 10 to 60 determined as the relative amount of hydrate represented by a peak in the X-ray diffraction (XRD) pattern at $2\theta = 5.66\text{\AA}$ when a hydrate level of 100 corresponds to the XRD peak height exhibited by a standard material constituting 0.6 wt% Pt on 150 m²/g alumina containing 7.2 wt% F wherein the fluoride has been deposited using an aqueous solution containing a high concentration of HF, i.e. 10 wt% HF, and greater, preferably 10 to 15 wt% HF and the material dried at 150°C for 16 hrs; (2) a surface nitrogen content N/Al ratio of 0.01 or less, preferably 0.007 or less, most preferably 0.004 or less as determined by X-ray photoelectron spectroscopy (XPS); (3) a bulk fluoride concentration of about 2 to 10 wt% and (4) a surface fluoride concentration, defined as the amount of fluoride present in a layer extending from the surface of the particle (e.g. 1/16 inch extrudates) to a depth of 1/100 inch of less than 3 wt%, preferably less than 1 wt%, most preferably less than 0.5 wt% fluoride in that zone provided that the surface fluoride concentration is less than the bulk fluoride concentration.

35 Another preferred catalyst is made by the procedure recited in U.S. Patent 4,900,707. The use of this particular catalyst for the production of lube base stock and blending stock by the isomerization of wax is the subject of U.S. Patent 4,937,399. That catalyst comprises a hydrogenating metal on fluorided alumina or material containing alumina support made by depositing the hydrogenation metal on the support and fluoriding said metal loaded support using acidic fluoride sources such as HF by any convenient technique such as spraying, soaking, incipient wetness, etc. to deposit between 2-10% F preferably 2-8% F. Following halogenation the catalyst is dried, typically at 120°C and then crushed to expose inner surfaces, and the crushed catalyst is double sieved to remove fines and uncrushed particles. This sized catalyst is 1/32 inch or less and typically from 1/64 to 1/32 inch in size across its largest cross-sectional dimension.

45 A most preferred catalyst is the subject of U.S. Patent 4,906,601. The use of that catalyst for wax isomerization is the subject of U.S. Patent 4,923,588.

50 That catalyst comprises a noble Group VIII metal on low fluoride content small particle size refractory metal oxide base. The catalyst is characterized by having a fluoride content in the range of 0.1 to up to but less than 2 wt%, preferably 0.1 to 1.5 wt%, more preferably 0.2 to 1.0 wt%, a particle diameter of less than 1/16 inch and a preferred noble Group VIII metal loading in the range of 0.1 to 2.0 wt%. The preferred small particle support is 1/20 inch trilobe alumina.

55 As one would expect, noble metal isomerization catalysts are extremely susceptible to deactivation by the presence of heteroatom compounds (i.e. N, O or S compounds) in the wax feed so care must be exercised to remove such heteroatom materials from the wax feed charges. When dealing with high purity waxes such as synthetic Fischer-Tropsch waxes, such precautions may not be necessary. In such cases, subjecting such waxes to very mild hydrotreating may be sufficient to insure protection for the isomerization catalyst. On the other hand, waxes obtained from natural petroleum sources contain quantities of heteroatom compounds as well as appreciable quantities of oil which contain heteroatom compounds. In such instances the slack waxes should be hydrotreated to reduce the level of heteroatom compounds to levels commonly accepted in the indus-

try as tolerable for feeds to be exposed to isomerization catalysts. Such levels will typically be a N content of about 1 to 5 ppm and a S content of about 1 to 20 ppm, preferably 2 ppm or less nitrogen and 5 ppm or less sulfur. Similarly, such slack waxes prior to hydrotreating should be deoiled to an oil content in the range of 0 to 35% oil, preferably 5 to 25% oil. The hydrotreating step will employ a typical hydrotreating catalyst such as
5 Co/Mo or Ni/Mo on alumina under standard, commercially acceptable conditions, e.g., temperature of 280 to 400°C, space velocity of 0.1 to 2.0 V/V/hr, pressure of from 500 to 3000 psig H₂ and hydrogen gas rates of from 500 to 5000 SCF/bbl. During this very mild hydrotreating step, very little conversion of hydrocarbons to lower molecular weight fractions occurs.

When dealing with Fischer-Tropsch wax it is preferred, from a processing standpoint, to treat such wax in
10 accordance with the procedure of U.S. Patent 4,943,672. The Fischer-Tropsch wax is treated with a hydrotreating catalyst and hydrogen to reduce the oxygenate and trace metal levels of the wax and to partially hydrocrack/isomerize the wax after which it is hydroisomerized under conditions to convert about 10 to 35 wt% of the hydrotreated Fischer-Tropsch wax to distillate and lighter fractions (343°C) by being contacted in a hydroisomerization zone with a fluorided Group VIII metal-on-alumina catalyst having (1) a fluoride concentration
15 ranging from about 2 to 10 percent based on the total weight of the catalyst, wherein the fluoride concentration is less than about 2.0 weight percent at the outer surface to a depth less than one one hundredth of an inch, (2) an aluminum fluoride hydroxide hydrate level greater than 60 where an aluminum fluoride hydroxide hydrate level of 100 corresponds to the X-ray diffraction peak height of 5.66Å for a reference material containing 0.6 wt% Pt and 7.2 wt% F on γ alumina having a surface area of about 150 m²/g prepared by impregnating γ alumina
20 containing platinum with an aqueous solution of hydrogen fluoride (11.6 wt% HF solution) followed by drying at 300°F and (3) a N/Al ratio by XPS of less than about 0.005. The hydrotreating is under relatively severe conditions including a temperature in the range 650 to 775°F, (about 343 to 412°C), a hydrogen pressure between about 500 and 2500 psig, a space velocity of between about 0.1 and 2.0 v/v/hr and a hydrogen gas rate between about 500 and 5000 SCF/bbl. Hydrotreating catalysts include the typical Co/Mo or Ni/Mo on alumina as well
25 as other combinations of Co and/or Ni and Mo and/or W on a silica/alumina base. The hydrotreating catalyst is typically presulfided but it is preferred to employ a non-sulfided hydrotreating catalyst.

As is taught in U.S. Serial No. 283,664 filed December 13, 1988, it is preferred that the isomerization reaction be conducted to a level of conversion such that about 40% and less, preferably 15 to 35%, most preferably
30 20 to 30%, unconverted wax remains in the fraction of the isomerate boiling in the lube boiling range sent to the dewaxing unit. The fraction of unconverted wax is calculated as (unconverted wax/ unconverted wax + dewaxed oil) X 100. The amount of unconverted wax in the 370°C oil fraction is taken to be the amount of wax removed or recovered from said oil fraction upon dewaxing. The total product from the isomerization unit is fractionated into a lube oil fraction boiling in the 330°C range, preferably in the 370°C range or even higher. This lube oil fraction is solvent dewaxed, preferably using a 20/80 v/v mixture of methyl ethyl ketone/methyl isobutyl
35 ketone, and unconverted wax is recycled for further isomerization by being fed either to the fresh feed reservoir or directly to the isomerization unit.

It is taught in copending application US Ser. No. 283,664 that hydroisomerate product produced from a microwax, e.g. Bright Stock slack wax, can be fractionated prior to dewaxing to yield a "broad heart cut" identified as the fraction boiling between about 330 and 600°C, preferably 370 and 580°C, and a heavy bottoms
40 fraction boiling above about 580 to 600°C. It is also taught that the heavy bottoms fraction contains appreciable wax and can be recycled for further isomerization by being sent to the isomerization unit directly, or if any hydrotreating or deoiling is deemed necessary or desirable then the fractionator bottoms may be sent to the fresh feed reservoirs and combined with the wax therein for hydrotreating prior to being sent to the isomerization zone.

However, the heavy bottoms fraction boiling above about 580-600°C is composed of much higher molecular weight molecules than the fresh feed, which typically also contains material boiling in the range 360-600°C. The 580-600°C fraction is not optimally handled by processing it with the whole feed to the hydroisomerization reactor.
45

It has been found in the present invention that more efficient use is made of the approximately 580-600°C fractionator bottoms material, by subjecting it to a severe hydrotreating step alone rather than to paired mild hydrotreating/hydroisomerization steps. The 580-600°C heavy bottoms fraction contains highly isomerized material. The conversion required to produce desirable oil from it is not further isomerization, which would lower the viscosity index of the oil, increase its volatility and produce a very viscous oil, but rather, molecular weight reduction. Molecular weight reduction accomplished by a severe hydrotreating step, lowers the boiling range
50 of the fractionator bottoms material to the more desirable 330-600°C, or most preferred 370-580°C range. This means that the viscosity of the fractionator bottoms material is lowered to a more desirable value, and the yield of 5.6-5.9 cSt/100°C oil recoverable from this fraction is substantially increased.

In addition, the yield of 370-580°C wax recovered from this fraction by a dewaxing step is also increased

over that recoverable from paired hydrotreating/hydroisomerization steps. This wax can be recycled for further isomerization to oil by being sent to the isomerization unit directly, or if any hydrotreating or deoiling is deemed necessary or desirable then it may be sent to the fresh feed reservoirs and combined with the wax therein for hydrotreating and/or deoiling prior to being sent to the isomerization zone.

5 It has also been found that prior to fractionation of the isomerate into various cuts and dewaxing said cuts the total liquid product from the isomerization unit can be advantageously treated in a second stage at mild conditions using the isomerization catalyst or simply a noble Group VIII or refractory metal oxide catalyst to reduce the levels of polynuclear aromatics and other contaminants in the isomerate and thus yield an oil of improved daylight stability. This aspect is covered in copending application USSN 283,659, filed December 13, 10 1988.

In that embodiment the total isomerate is passed over a charge of the isomerization catalyst or over just noble Group VIII on transition alumina. Mild conditions are used, e.g. a temperature in the range of about 170 to 270°C, preferably about 180 to 220°C, at pressures of about 300 to 1500 psig H₂, preferably 500 to 1000 psig H₂, a hydrogen gas rate of about 500 to 10,000 SCF/bbl feed, preferably 1000 to 5000 SCF/bbl feed and a flow velocity of about 0.25 to 10 V/V/hr, preferably about 1 to 4 V/V/hr. Higher temperatures than those recited may be employed if pressures in excess of 1500 psi are used, but such high pressures may not be practical.

The total isomerate can be treated under these mild conditions in a separate, dedicated unit or it can be stored in tankage and subsequently passed through the aforementioned isomerization reactor under said mild conditions. It has been found to be unnecessary to fractionate the first stage product prior to this mild second stage treatment. Subjecting the whole product to this mild second stage treatment produces an oil product which upon subsequent fractionation and dewaxing yields a base oil exhibiting a high level of daylight stability and oxidation stability. These base oils can be subjected to subsequent hydrotreating under conventional conditions to remove undesirable nitrogen and/or sulfur compounds using conventional catalysts such as HDS-22, RF-840 or HDN-30 (e.g., Co/Mo or Ni/Mo on alumina).

25 In the practice of the present invention, the isomerate from the hydroisomerization zone is fractionated to recover a light product typically boiling below about 330 to 370°C, a heart cut fraction boiling between about 330 to 370+°C and about 580 to 600°C and a heavy bottoms fraction boiling above about 580 to 600+°C.

The heart cut fraction is subjected to dewaxing as previously described with the recovered wax being recycled to the isomerization zone.

30 In contrast with the prior practice which recycled the heavy bottoms fraction to the wax hydrotreater (if necessary) prior to recycle to the hydroisomerization zone, it has been discovered and is disclosed herein that the heavy bottoms fraction boiling above about 580 to 600+°C can be sent to a severe hydrotreating zone for conversion directly to a high quality light oil without the necessity of the added step of recycle to the hydroisomerization zone.

35 The severe hydrotreating of the heavy bottoms fraction boiling above about 580 to 600+°C is conducted in the presence of any of the standard hydrotreating catalysts containing one or more metals, oxides or sulfides of Group VIB, Group VII and/or non noble Group VIII on a refractory metal oxide support, such as alumina or silica/alumina. Typical catalysts include Co/Mo on alumina, Ni/Mo on alumina, Co/Ni/Mo on alumina, Ni/W on alumina, etc.

40 Severe hydrotreating conditions include operation at a temperature above about 300°C, preferably in the range 350 to 450°C, a pressure in the range 500 to 5000 psig, preferably 1000 to 2500 psig, a hydrogen gas treat rate of 1000 to 3000 SCF H₂/bbl feed, preferably 1000 to 3000 SCF H₂/bbl feed and a space velocity of 0.1 to 10 v/v/hr, preferably 0.25 to 2.0 v/v/hr.

45 The effluent from this severe hydrotreating step is fractionated into a light oil of superior quality. This fractionation of the severely hydrotreated bottoms fraction may be conducted in a separate, dedicated fractionation tower or, preferably, the severely hydrotreated bottoms fraction is fed to the hydroisomerate fractionation tower for fractionation therein simultaneously with the wax isomerate. The severely hydrotreated bottoms fraction is fractionated to recover a heart cut fraction boiling between about 330 to 370°C and 580 to 600°C range. This heart cut fraction either by itself or with the isomerate heart cut fraction is dewaxed to produce a lube oil stock or blending stock. The dewaxed heart cut fraction recovered from the severely hydrotreated bottoms fraction is an oil of high viscosity index and as compared to a similar boiling fraction recovered from the isomerization of a bottoms fraction, is of lower viscosity. Alternatively the severely hydrotreated bottoms fraction can be dewaxed prior to fractionation.

55 The severely hydrotreated bottoms fraction prior to refractionation can be cycled to mild condition hydroisomerization in accordance with USSN 283,659 cited above to improve daylight stability or it can be fractionated and dewaxed and sent directly to tankage for use as such or for blending with other oil fractions.

Figure 1 presents an integrated schematic of the total wax isomerization process including heavy bottoms fraction severe hydrotreating and fractionation.

Slack wax or Fischer-Tropsch wax is sent from storage vessel (1) via line (2) to a wax hydrotreater (3) to remove any heteroatom compounds or oxygenates which could contaminate or deactivate the wax hydroisomerization catalyst in hydroisomerization units 4 and 5. Hydroisomerization unit 4 is run at standard hydroisomerization conditions while hydroisomerization unit (5) is run at mild, less severe conditions to improve the daylight stability of the hydroisomerate from unit (4). The isomerate is fed via line (6) to the fractionator (7) wherein the isomerate is fractionated into a light fuels fraction boiling below about 330 to 370°C recovered via line (8), a heart cut boiling between about 330 to 370°C and 580 to 600°C which is sent via line (9) to the solvent dewaxer (10) wherein a high quality dewaxed oil is separated from any unconverted wax present in the heart cut fraction. The oil is recovered via line (11) and the wax is recovered via line (12) for recycle to the isomerization process, being sent by either line (12) directly to the hydroisomerization and (4) or via line (12a) to the wax hydrotreater (3) before being sent to the hydroisomerization unit (4).

A heavy bottoms fraction boiling above about 580 to 600°C is recovered from fractionator (7) via line (13) and sent to the severe hydrotreater (14) wherein the heavy bottoms fraction is converted into a high quality light oil/wax mixture. The hydrotreated product is sent via line 15 to fractionator 7 wherein the 330 to 370°C - 580 to 600°C fraction of the hydrotreated material is recovered with the 330 to 370°C - 580 to 600°C fraction recovered from the wax isomerate. Alternatively the hydrotreated heavy bottoms fraction is sent via line 15(a) to the mild condition hydroisomerization zone 5 to improve its daylight stability. The hydrotreated heavy bottoms fraction is therein combined with the wax isomerate and subsequently fractionated in fractionation zone 7 to result in, in combination with the wax isomerated fractionated in fractionator (7), an increased yield of light, high quality oil.

Example

Fractionator bottoms (583+°C) from the single-pass hydroisomerization of a Bright Stock slack wax was subjected to two experiments: hydrotreating using sulphided KF-840 (Ni/Mo on alumina) catalyst under severe conditions (0.5 v/v/h, 420°C, 1000 psig, 2500 SCF/B treat gas rate), or hydroisomerization using a 0.6 wt% Pt/5.6 wt% F/alumina catalyst (340°C, 1.0 v/v/h, 1000 psig, 5000 SCF/B treat gas rate). The products were fractionated by HiVac distillation, and dewaxed. Yields and physical properties of the oils produced by the two processes are given in Table 1.

There are three significant differences between the two conversion products. First, product from the hydrotreating experiment was not biased to high viscosity as was that from recycle hydroisomerization. For example, 370-562°C dewaxed oil obtained by hydrotreating had a viscosity of 5.10 cSt/100°C, while the 370-568°C dewaxed oil from hydroisomerization had a viscosity of 5.99 cSt/100°C. Thus, a 5.7 cSt dewaxed oil could be prepared from the hydrotreated material (by the removal of a light fraction), but not from the hydroisomerization product.

Second, dewaxed oil Viscosity Indices were very high (>150) for 5+ cSt/100°C hydrotreated oils. This is higher than those for once-through Bright Stock slack wax hydroisomerate oils (VI's approximately 145) and significantly higher than those of oils from hydroisomerization of the fractionator bottoms material (VI approximately 136).

Third, the hydrotreated product contained more wax than the hydroisomerate product. For example, 6.4 cSt hydrotreated oil contained 25.6 wt% dry wax, while a 6.6 cSt hydroisomerate oil contained only 5.1 wt% dry wax. The higher wax content is desirable, as this can be recycled to hydroisomerization to produce 5.7 cSt/100°C oil. As well, dewaxer feeds having very low wax contents can be difficult to dewax. The wax content of the hydrotreated product is in line with those found for 600N slack wax hydroisomerates at the same conversion severity.

Dewaxed oils of greater than 6.0 cSt/100°C could be prepared from the hydroisomerate product, but due to the broad cut width of the oils, (370+°C) volatility would probably be a concern. The hydroisomerate product is best suited to production of higher viscosity grades of oil (say, >7.0 cSt/100°C). Lighter oils could be prepared from the hydrotreated product, and would probably have better volatility (narrower cut width and better boiling point/viscosity relationship due to high VI's).

It is envisioned that hydrotreating of the fractionator bottoms could be carried out immediately following fractionation. The hydrotreated stream could then be recycled back to the fractionation tower or to second stage (low temperature) hydroisomerization. Alternately, the fractionator bottoms from once-through operation could be sent to tankage. They could then be blocked through the slack wax pre-hydrotreater operating this time under severe conditions, and then sent to second stage hydroisomerization or to the fractionation tower. The new heart cut material from the fractionator (370-580°C) would proceed to dewaxing, while the new fractionator bottom stream would again be recycled to the hydrotreater. This scheme is a more efficient method of reducing the molecular weight of heavy molecules than is hydroisomerization, and also leads to a quality upgrade of the

heavy material so that its oils more nearly match (or exceed) the quality of oils produced from 600N slack waxes.

The hydrotreating conditions used in these experiments were severe (420°C, 0.5 v/v/h). KF-840 Ni/Mo on alumina was selected as the catalyst to hydrotreat raw slack waxes because it causes minimal hydrocarbon cracking during hydrodenitrogenation and hydrodesulphurization. The present experiments were designed to carry out considerable hydrocarbon conversion. This is thus not simply hydrotreating to remove contaminants, but a new process to change the nature of the heaviest hydrocarbons. A more acidic catalyst such as a silica/alumina base hydrotreating catalyst or halogenated base support non-noble hydrotreating catalyst may be preferred as the hydrotreating catalyst so that milder process conditions can be used. Lower temperature operation is also desirable for improved daylight stability of the hydroisomerate oils. The catalyst can be sulphided or non-sulphided.

5

10

15

20

25

30

35

40

45

50

55

5
10
15
20
25
30
35
40
45
50
55

TABLE 1

COMPARISON OF DEWAXED OIL BLENDS FOR HYDROTREATED AND HYDROISOMERIZED BRIGHT STOCK FRACTIONATOR BOTTOMS MATERIAL*

HYDROTREATED PRODUCT	
HIVAC CUT POINTS, °C	370-562
YIELD DEWAXED OIL/FEED W% DRY WAX	21.8 44.7 37.4 24.5
VISCOSITY, CST, 100°C	14.99
VISCOSITY INDEX	152 153
POUR POINT, °C	-9
<hr/>	
HYDROISOMERIZED PRODUCT	
HIVAC CUT POINTS, °C	370-398
YIELD DEWAXED OIL/FEED W% DRY WAX	4.2 41.0 5.1
VISCOSITY, CST, 100°C	2.56
VISCOSITY INDEX	117
POUR POINT, °C	-21

*570+°C fractionator bottoms material from single pass hydroisomerization of a Bright Stock slack wax

- United States' patent applications serial numbers USSN 283,664 and 283,659 correspond with European patent applications numbers 88311989.3 and 88311988.5, respectively.

5 **Claims**

1. A method for producing a light oil of low viscosity and high viscosity index out of a heavy bottoms fraction boiling above a cut-off temperature in the range 580 - 600°C, obtained by the fractionation of isomerate produced by the hydroisomerization of heavy waxes, said method comprising the steps of severely hydrotreating the heavy bottoms fraction over a catalyst and re-fractionating the severely hydrotreated fraction.
10
2. The method of claim 1 where the severe hydrotreating conditions include a temperature in the range of from 300 to 500°C, a pressure in the range 500 to 5000 psig (3.45 to 34.48MPa), a hydrogen treat gas rate of 250 to 5000 SCF H₂/bbl feed (0.0445 to 0.89 m³H₂/liter feed) and a space velocity of 0.1 to 10.0 v/v/hr.
15
3. The method of claim 1 or claim 2 wherein the severe hydrotreating conditions include a temperature in the range 350 to 450°C, a pressure in the range 1000 to 2500 psig (6.895 to 17.238 MPa), a hydrogen gas treat rate of 1000 to 3000 SCF H₂/bbl feed (0.178 to 0.534 m³H₂/liter feed) and a space velocity of 0.25 to 2.0 v/v/hr.
20
4. The method of any one of claims 1 to 3 wherein the catalyst is selected from the metals, oxides and sulfides of Group VIB and non-noble Group VIII on a refractory metal oxide support.
25
5. The method of any one of claims 1 to 4 comprising a dewaxing step performed prior to or after the re-fractionation step.
6. The method of any one of claims 1 to 5 wherein the re-fractionation step is practised to recover the oil fraction boiling in the 330°C to 580°C - 600°C range.
30
7. The method of any one of claims 1 to 6 wherein the severely hydrotreated bottoms fraction is subjected to mild condition hydroisomerization prior to re-fractionation.

35

40

45

50

55

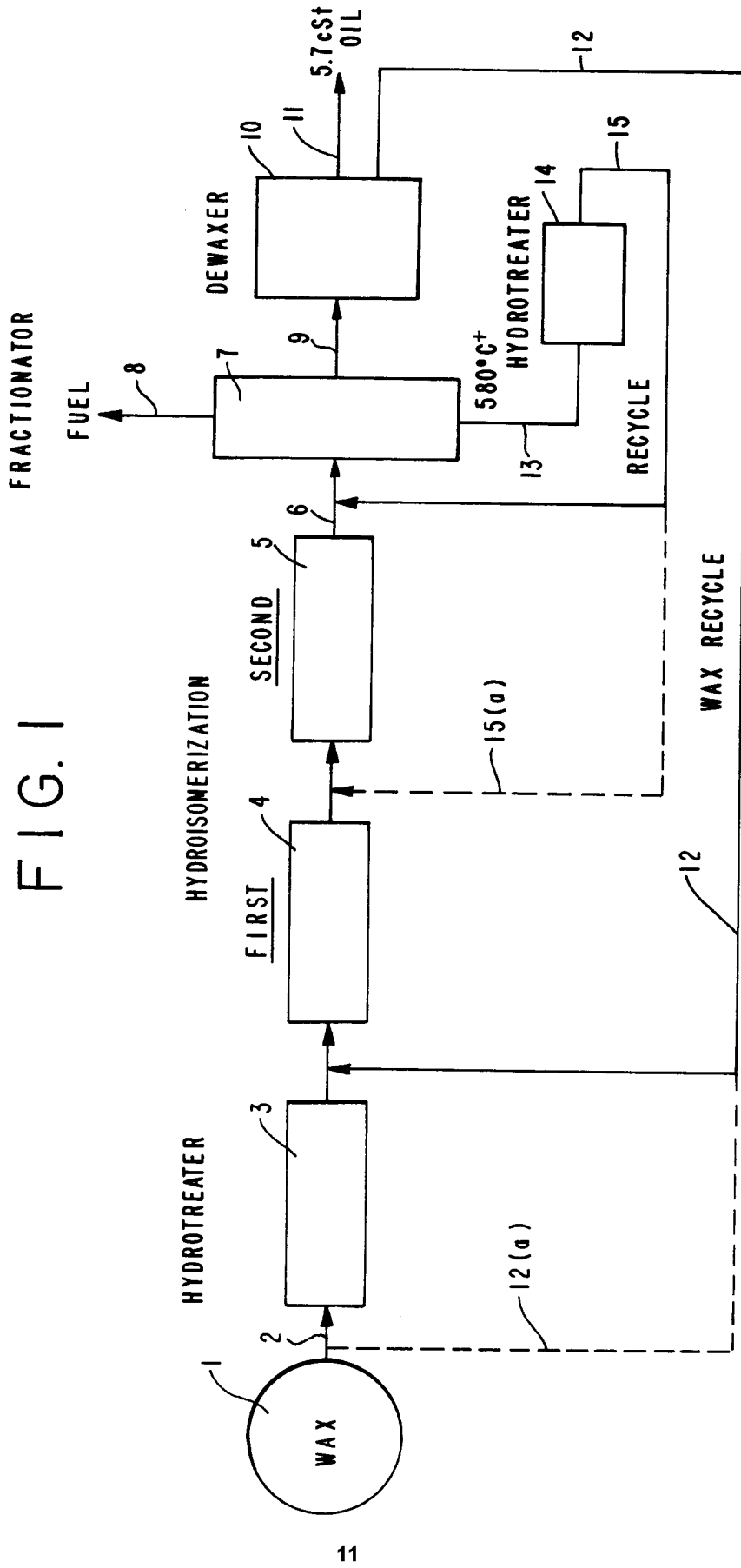



European Patent Office

EUROPEAN SEARCH REPORT

Application Number

EP 91 30 7363

DOCUMENTS CONSIDERED TO BE RELEVANT			
Category	Citation of document with indication, where appropriate, of relevant passages	Relevant to claim	CLASSIFICATION OF THE APPLICATION (Int. Cl.5)
A	EP-A-0 323 724 (EXXON) * claim 1 *	1, 4	C10G65/04
			TECHNICAL FIELDS SEARCHED (Int. Cl.5)
			C10G
The present search report has been drawn up for all claims			
Place of search THE HAGUE		Date of completion of the search 17 OCTOBER 1991	Examiner OSWALD DE HERDT
CATEGORY OF CITED DOCUMENTS X : particularly relevant if taken alone Y : particularly relevant if combined with another document of the same category A : technological background O : non-written disclosure P : intermediate document		T : theory or principle underlying the invention E : earlier patent document, but published on, or after the filing date D : document cited in the application L : document cited for other reasons & : member of the same patent family, corresponding document	

EPO FORM 1503 01.92 (P0401)